

R E P O R T R E S U M E S

ED 018 950

EF 001 338

DENTAL SCHOOL PLANNING.

BY- GALAGAN, DONALD J.

PUBLIC HEALTH SERVICE (DHEW), WASHINGTON, D.C.

REPORT NUMBER PHS-940

AMERICAN DENTAL ASSN., WASHINGTON, D.C.

DEPARTMENT OF HEALTH, EDUCATION AND WELFARE

EDRS PRICE MF-\$0.50 HC-\$4.96 122P.

DESCRIPTORS- *DENTAL SCHOOLS, *EDUCATIONAL FACILITIES, *EDUCATIONAL SPECIFICATIONS, *FACILITY GUIDELINES, *MEDICAL SCHOOLS, COLLEGE PLANNING, DATA COLLECTION, DENTAL CLINICS, HEALTH SERVICES,

THIS DISCUSSION PRESENTS A COMPLETE PICTURE OF THE CURRENT STATE OF DENTAL EDUCATION WITH SUGGESTIONS FOR MEETING THE DEMANDS FOR DENTAL STAFF AND FACILITIES. THE AREAS INVESTIGATED ARE (1) OBJECTIVES IN DENTAL EDUCATION--COURSES, TEACHING MODES, INNOVATIONS IN CURRICULUM, COORDINATION OF BASIC AND CLINICAL INSTRUCTION, (2) FACILITY REQUIREMENTS--UNDERGRADUATE NEEDS, UTILIZATION, (3) COSTS-- GROSS AREA, INITIAL MAINTENANCE, REMODELING, (4) SITE SELECTION, (5) DESIGN AND STRUCTURE OF PHYSICAL PLANT--MODULAR PLANNING, LABORATORIES AND OFFICES, FURTHER EXPANSION POTENTIAL, (6) INNER-PLANT SPACE RELATIONSHIPS--TRAFFIC PATTERNS AND COMPETING DEMANDS, (7) SCIENCE FACILITIES--LABORATORIES, TEACHING LABORATORIES, SPECIAL FACILITIES, DISSECTION ROOM, (8) PRE-CLINICAL FACILITIES AND EDUCATIONAL TV, (9) SPACE ALLOCATION--OPEN VS. CUBICLE TYPE CLINIC, (10) TEACHING AND RESEARCH--CLASSROOMS, LECTURE ROOMS, LIBRARY, STUDY, REFERENCE, RESEARCH, (11) THE CLINIC-- RECEPTION, SCREENING, EXAMINATION AND DIAGNOSIS, AND TREATMENT AREA, (12) VISUAL AIDS AND TV, AND (13) SUPPORTING SERVICES--ANIMAL QUARTERS, STORAGE AND TECHNICAL SHOPS. THE APPENDIXES INCLUDE FORMS FOR STUDYING AND OUTLINING EACH ELEMENT OF DENTAL SCHOOLS. THE QUESTIONS COVER NATURE, DIMENSIONS, SPECIAL REQUIREMENTS OF NEED, SPACE, LOCATION, USE, SERVICES, UTILITIES AND REQUIRED EQUIPMENT. THIS DOCUMENT IS ALSO AVAILABLE FROM THE GOVERNMENT PRINTING OFFICE, WASHINGTON, D.C. 20025, PRICE \$0.70. (BH)

ED018950

DENTAL SCHOOL PLANNING

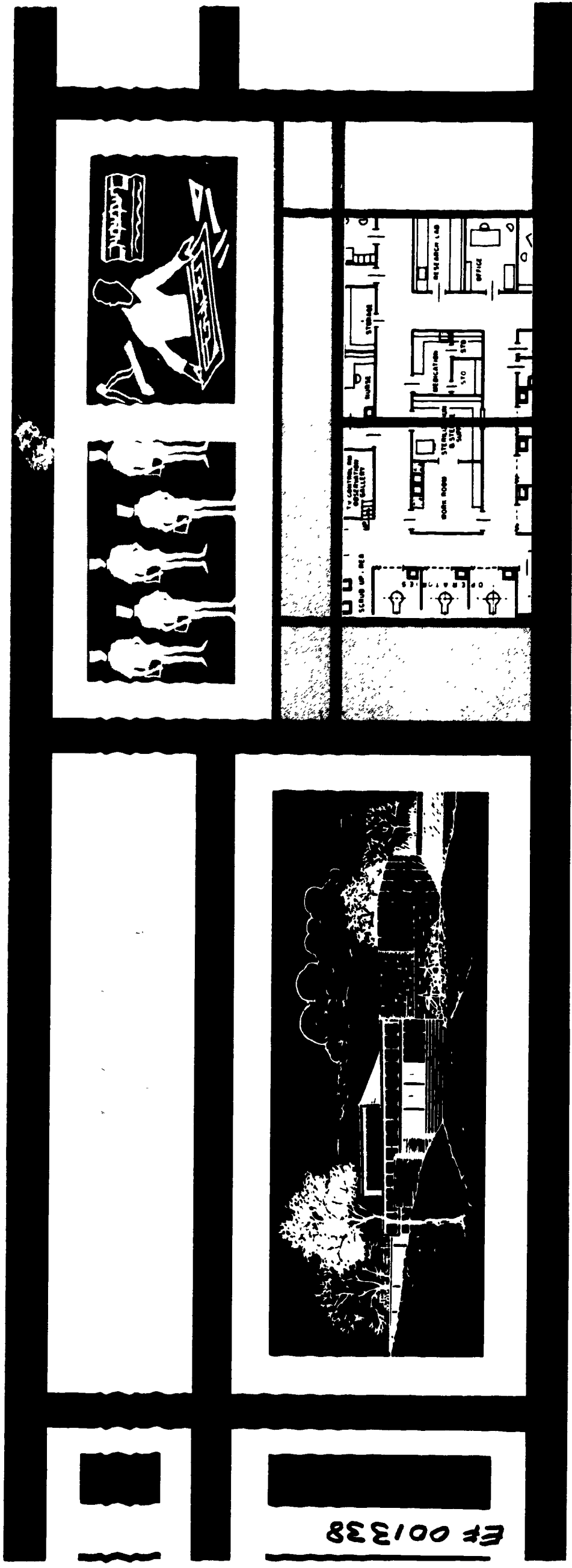

ET 001338



PUBLIC HEALTH SERVICE PUBLICATION NO. 940

United States Government Printing Office, Washington 25, D.C., 1962 • Price: 70¢

**First printed October 1962
Reprinted May 1963**

**U.S. DEPARTMENT OF HEALTH, EDUCATION & WELFARE
OFFICE OF EDUCATION**

**THIS DOCUMENT HAS BEEN REPRODUCED EXACTLY AS RECEIVED FROM THE
PERSON OR ORGANIZATION ORIGINATING IT. POINTS OF VIEW OR OPINIONS
STATED DO NOT NECESSARILY REPRESENT OFFICIAL OFFICE OF EDUCATION
POSITION OR POLICY.**



DENTAL SCHOOL PLANNING

**prepared by
PUBLIC HEALTH SERVICE
in cooperation with
COUNCIL ON DENTAL EDUCATION:
AMERICAN DENTAL ASSOCIATION
and
AMERICAN ASSOCIATION OF DENTAL SCHOOLS**

STUDY STAFF—DIVISION OF DENTAL PUBLIC HEALTH AND RESOURCES

**Donald J. Galagan, D.D.S., Chief • Walter J. Pelton, D.D.S., Chief, Manpower and Education Branch
Samuel J. Wycoff, D.M.D. • Herbert H. Hollweg, R.A.
Ruth D. Bothwell • Mary N. Gailbreath • Alice E. Haywood**

**U.S. DEPARTMENT OF HEALTH, EDUCATION, AND WELFARE • PUBLIC HEALTH SERVICE
Division of Dental Public Health and Resources • Manpower and Education Branch, Washington 25, D.C.**

Dental School Planning is designed as a general but practical guide which will serve programming committees as an orientation to the fundamentals of planning, and architects and engineers as an introduction to a specialized educational system. It makes no effort to provide either categorical answers to the question of how dental schools should be built or step-by-step instruction in the actual design and construction of a school plant. Rather, it discusses the broader initial issues which must be resolved before an architect undertakes the final design of a school.

The guide brings together a variety of information on trends in dental education, space utilization and allocation, site selection, and costs. It covers in some detail the points to be considered in planning the components of a dental school—the laboratories, the clinics, the special facilities required for students, faculty, researchers and administrative personnel. An appendix provides space estimates for schools of different sizes.

Much of the information upon which *Dental School Planning* is based was obtained through a survey conducted by the Manpower and Education Branch of the Division of Dental Public Health and Resources, U.S. Public Health Service; the American Association of Dental Schools; and the Council on Dental Education of the American Dental Association.

The deans of all the Nation's dental schools participated in the survey, each of them giving detailed replies to a two-part questionnaire.

The first series of questions was devoted to physical facilities—the space already available for the various activities, as well as the additional space required to accommodate those activities more adequately. The second series focused upon

FOREWORD

curriculum content, teaching methods, and educational philosophies, and the manner in which these influence and, in turn, are influenced by the utilization of space.

Further material was gathered through personal interviews with the deans, department heads, and planning and operations staffs of the different schools, through consultations with specialists in facilities design and construction, and through on-site studies of dental school activities and facilities.

We are grateful to the deans for their thoughtful responses to the survey questions and to all those who, in other ways, gave counsel and guidance. We are particularly indebted to the members of a special committee nominated by the Council on Dental Education and the American Association of Dental Schools to assist in the preparation of this guide.

- Dr. Lester W. Burket, Dean of the School of Dentistry, University of Pennsylvania and representing the American Association of Dental Schools.
- Mr. Benjamin Miller, Acting Secretary of the Council on Dental Education, American Dental Association.
- Dr. R. E. V. Miller, Chairman of the Committee on Special Studies, Council on Dental Education, American Dental Association.
- Dr. Raymond Nagle, Dean of the College of Dentistry, New York University, and member of the Committee on Special Studies, Council on Dental Education, American Dental Association, and President of the American Association of Dental Schools at the time that the Committee was formed.
- Mr. R. H. Sullens, Executive Secretary of the American Association of Dental Schools.

This Committee not only reviewed the text, but also supplied the encouragement and judgment necessary for the completion of the project.

In addition, it is a pleasure to acknowledge the assistance of Mr. Julian Cook, Coordinator on the Building Program of Howard University. The several members of the study staff on medical school planning, Division of Hospital and Medical Facilities and Division of Public Health Methods, Public Health Service, contributed materially to the preparation of the guide. Finally, special thanks are due Dr. Leland E. Weyer, Public Health Service (retired), for his invaluable contributions to the planning and completion of the study. *Dental School Planning* is a joint venture which, it is hoped, will prove a milestone in dental education.

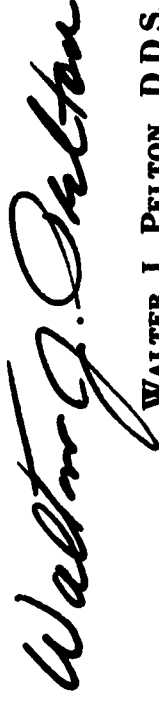

WALTER J. PELTON, D.D.S.
Chief, Manpower and Education Branch
Division of Dental Public Health and Resources

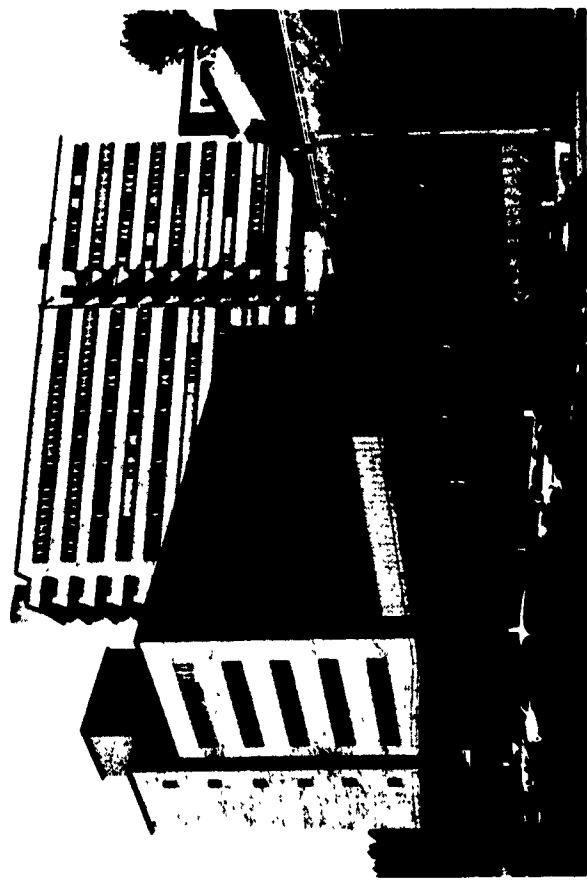
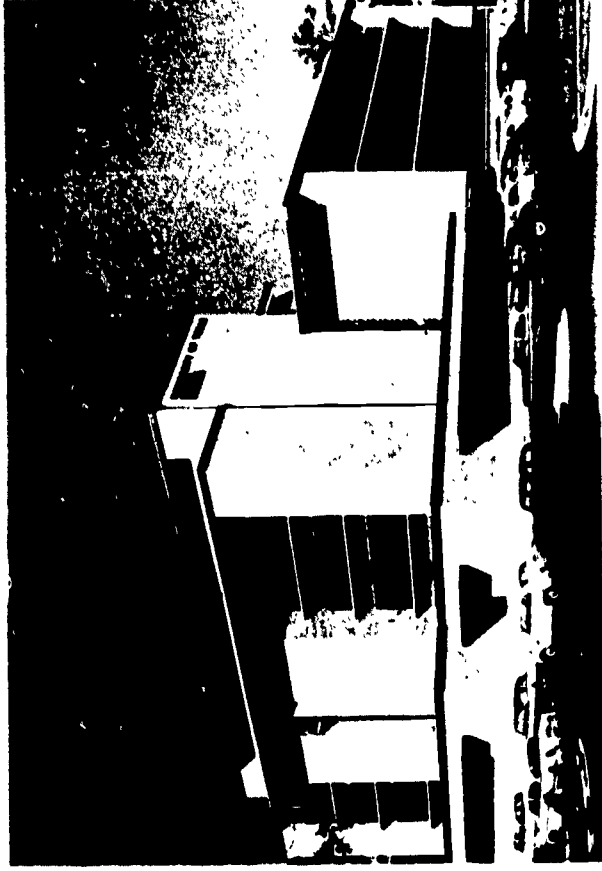

TABLE OF CONTENTS

Part 1. INTRODUCTION	PAGE
1. THE CHANGING ENVIRONMENT OF DENTAL EDUCATION -----	1
Part 2. PROGRAMMING	
2. PROGRAMMING—AN INTRODUCTION-----	4
3. DEFINING OBJECTIVES-----	7
4. OUTLINING NEEDED FACILITIES-----	11
5. ESTIMATING COSTS-----	13
Part 3. OTHER PLANNING CONSIDERATIONS	
6. SELECTING THE SITE-----	18
7. THE PHYSICAL PLANT: DESIGN AND STRUCTURE-----	20
8. WITHIN THE PHYSICAL PLANT: SPACE RELATION-SHIPS -----	25
Part 4. BASIC SCIENCE FACILITIES	
9. BASIC SCIENCE FACILITIES—IN GENERAL-----	29
10. BASIC SCIENCE LABORATORY FACILITIES-----	32



Part 5. CLINICAL AND PRECLINICAL FACILITIES	PAGE
11. PRECLINICAL FACILITIES.....	41
12. CLINICS: FUNCTION AND OPERATION.....	43
13. CLINICS: SPACE ALLOCATIONS AND RELATION- SHIPS.....	52

Part 6. COMMON FACILITIES FOR TEACHING AND RESEARCH	
14. INSTRUCTION ROOMS, STUDY AREAS AND LI- BRARY FACILITIES.....	59
15. EDUCATIONAL TELEVISION AND OTHER VISUAL AIDS.....	63
16. SUPPORTING SERVICES FOR LABORATORIES AND CLINICS.....	67

Part 7. SPECIAL FACILITIES FOR TEACHING AND RESEARCH	
17. FACULTY FACILITIES.....	72
18. GRADUATE AND POSTGRADUATE FACILITIES.....	75
19. AUXILIARY PERSONNEL.....	75

Part 8. GENERAL SUPPORTING FACILITIES	PAGE
20. ADMINISTRATIVE FACILITIES.....	78
21. STUDENT FACILITIES.....	80
22. GENERAL MAINTENANCE AND BUILDING SERV- ICES.....	82

Part 9. CONCLUSION	
23. PLANNING FOR THE FUTURE.....	85

Part 10. APPENDIXES	
I. SPACE DESCRIPTION FORM.....	88
II. SPACE ALLOCATION TABLES.....	89
A. SUMMARY TABLES.....	90
B. BASIC SCIENCE FACILITIES (INCLUDING GRADUATE, POSTGRADUATE, AND FACULTY FACILITIES).....	92
C. CLINICAL (AND PRECLINICAL) FACILITIES (IN- CLUDING GRADUATE, POSTGRADUATE, AND FACULTY FACILITIES).....	95
D. COMMON FACILITIES.....	101
E. GENERAL SUPPORTING FACILITIES.....	106
F. DENTAL AUXILIARY PROGRAMS.....	109
III. LIST OF FLOOR PLANS AND PHOTOGRAPHS.....	110
IV. REFERENCES.....	111
V. SELECTED BIBLIOGRAPHY.....	112

INTRODUCTION

1. THE CHANGING ENVIRONMENT OF DENTAL EDUCATION

Part

1 THE CHANGING ENVIRONMENT OF DENTAL EDUCATION

The shortage of training facilities, which is beginning to be of concern to every branch of higher learning, is particularly severe in dental education. And in dental education the shortage of facilities is compounded by the fact that many school plants are obsolescent and unsuitable to the changes taking place in the method and content of the dental educational process.

THE SCHOOL SHORTAGE AND MANPOWER SUPPLY

That for a generation there have not been enough dental educational facilities has resulted in a manpower shortage more acute than that in any other health profession. Ten dental schools have been added in the United States since the end of World War II. Even so, the country has proportionately fewer dentists today than it had before the war. Further expansion of educational facilities is planned, yet its completion would not permit the training of enough additional dentists to halt the decline in proportionate supply, much less to reverse it. By 1975, in fact, the national dental force would total only 118,000 dentists—16,000 below the number required to maintain the current ratio.

If we do nothing more than prevent this further decline in proportionate supply, enough construction over and above that already anticipated must be achieved to provide places for 2,700 additional graduates, the equivalent of 27 new dental schools, each of them larger than today's average school.

RIISING DEMANDS FOR DENTAL SERVICES: A PROBLEM COMPOUNDED

Attainment of such training capacity would nearly double the annual number of dental school graduates—6,200 compared with 3,200. Yet, demands for service are increasing rapidly, and holding the dentist-population ratio at its present level makes no allowance for the additional dentists required to meet the much sharper increases in demands for care which all leading observers foresee.

In its recently published report,¹ the Commission on the Survey of Dentistry points out that the mere perpetuation of today's ratio through 1975 would not permit the profession to meet those increases brought about by rising incomes alone. The Commission states further that before the dental profession can act with full effectiveness in all areas demanding its attention—in prevention and practice, in teaching and research—the nation must double not the number of dental graduates but the *total dental supply*, providing a national force of 200,000 dentists by 1975.

BETTER UTILIZATION MUST ACCOMPANY EXPANSION

Because the construction necessary to the doubling of annual graduation rates will in itself be difficult to achieve, the Survey of Dentistry, in concert with other authoritative reports, urges that programs of expansion be accompanied by a thorough-going effort to heighten the effectiveness with which available professional knowledge and resources are employed.

The goal of greater individual effectiveness cannot be achieved by perpetuating the classic pattern of practice in which the dentist, working unassisted, expends his energies on tasks which require too much of his time and too little of his highest skills and competence. And the changes that informed critics deem essential are, almost without exception, dependent upon improvement in the dental educational process far more extensive than anything which could be realized within dental school facilities as we know them today.

See references on p. 111.

EMPLOYMENT AND TRAINING OF AUXILIARY PERSONNEL

The first of the steps recommended is the employment of far greater numbers of well-trained auxiliary personnel and the delegation to them of many of the less demanding duties now often performed by the dentist himself. But as the roles of these auxiliaries—the dental assistants, dental hygienists, and dental laboratory technicians—become more comprehensive, their education must be improved and facilities for their training greatly increased.

GOAL: TWICE AS MANY DENTAL SCHOOL GRADUATES

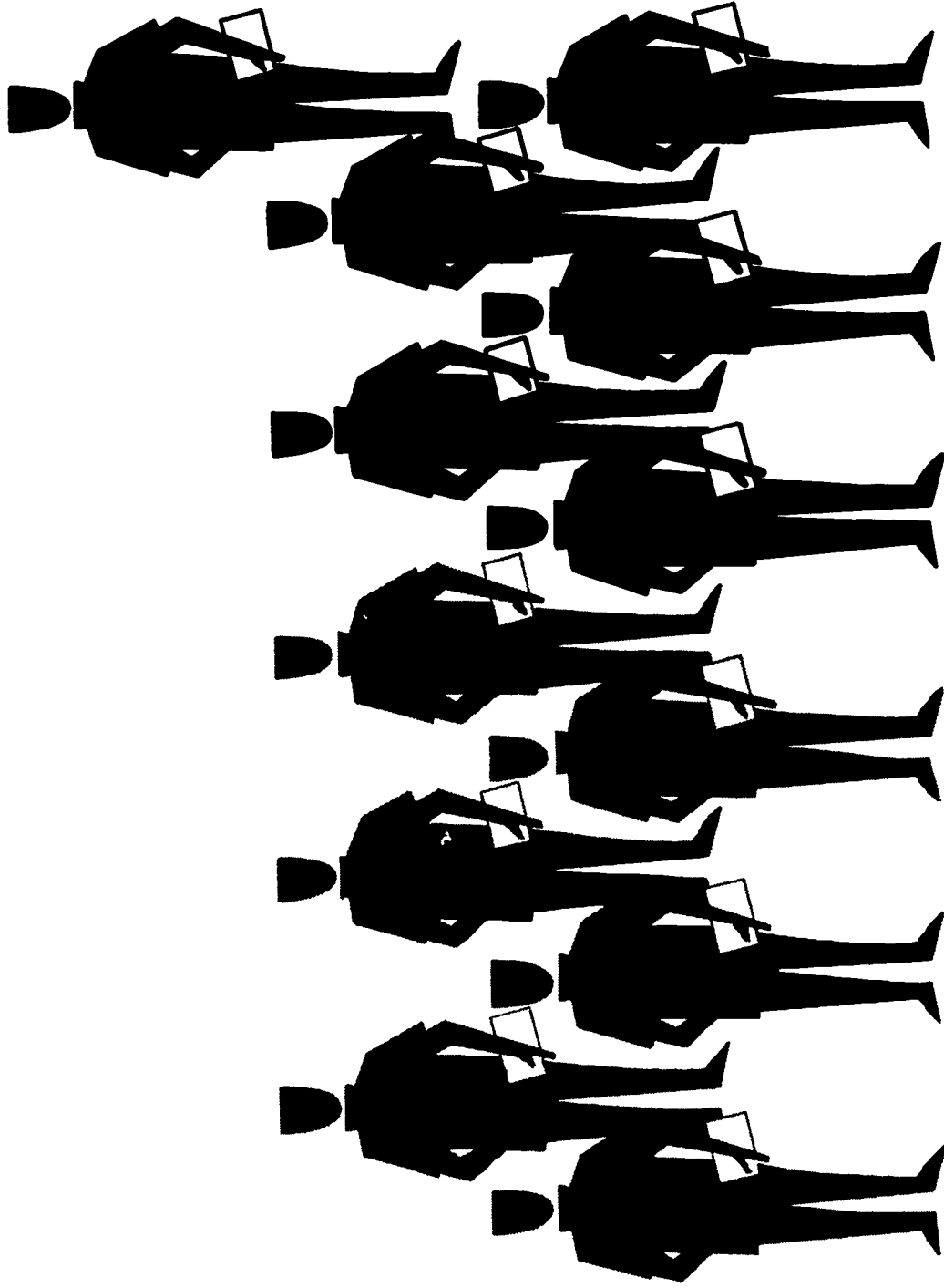

A NEW EMPHASIS ON RESEARCH

Dentistry's emergence as a shortage occupation also makes it imperative that the profession, while continuing its advances in restorative techniques, place far stronger emphasis upon the prevention and cure of diseases—an emphasis which in essence means the development of sustained and vigorous research programs in dental schools and the training of more dental research scientists.

STRONGER GRADUATE AND POSTGRADUATE EDUCATION

A more productive employment of auxiliaries and a fuller development of research and research training would equip the next generation of dentists for a more meaningful professional career. But such knowledge and skills cannot remain the exclusive possession of the newly trained. The dentist already in practice must be taught. The graduate student who wishes more instruction in fields other than clinical dentistry must also be taught.

And so, over the next few years, the dental school system, already short of space, must not only accommodate larger undergraduate enrollments but initiate—and house—the wide range of new and intensified activities demanded by a changing professional environment.

PROGRAMMING

- 2. PROGRAMMING—AN INTRODUCTION**
- 3. DEFINING OBJECTIVES**
- 4. OUTLINING NEEDED FACILITIES**
- 5. ESTIMATING COSTS**

Part

PROGRAMMING— 2 AN INTRODUCTION

The planning of a dental school involves far more than the commissioning of an architect to prepare designs and specifications. Whether they work as a committee of the whole or through subcommittees, those responsible for overall planning must undertake a great many activities which at first may seem to have little bearing on architectural design.

These activities range from an authoritative description of a specific educational process to a listing of equipment to the analysis of the advantages and disadvantages of a possible site. They will make decisions not only upon such questions as the teaching of the basic sciences and the size of the school library, but on the adequacy of parking spaces, the height of cubicle partitions and the size of the office of the dean.

The foundation of planning is the preparation of the written program—a statement which defines the school's objectives, spells out the facilities required to meet them, and gives preliminary estimates of costs.

THE VALUE OF A WRITTEN PROGRAM

One architect said of programming that it "makes of architecture a purposeful art; without it a project has about the same direction as a child's building of blocks."² Certainly the importance of a well-considered and carefully presented written building program cannot be over-estimated.

See references on p. 111.

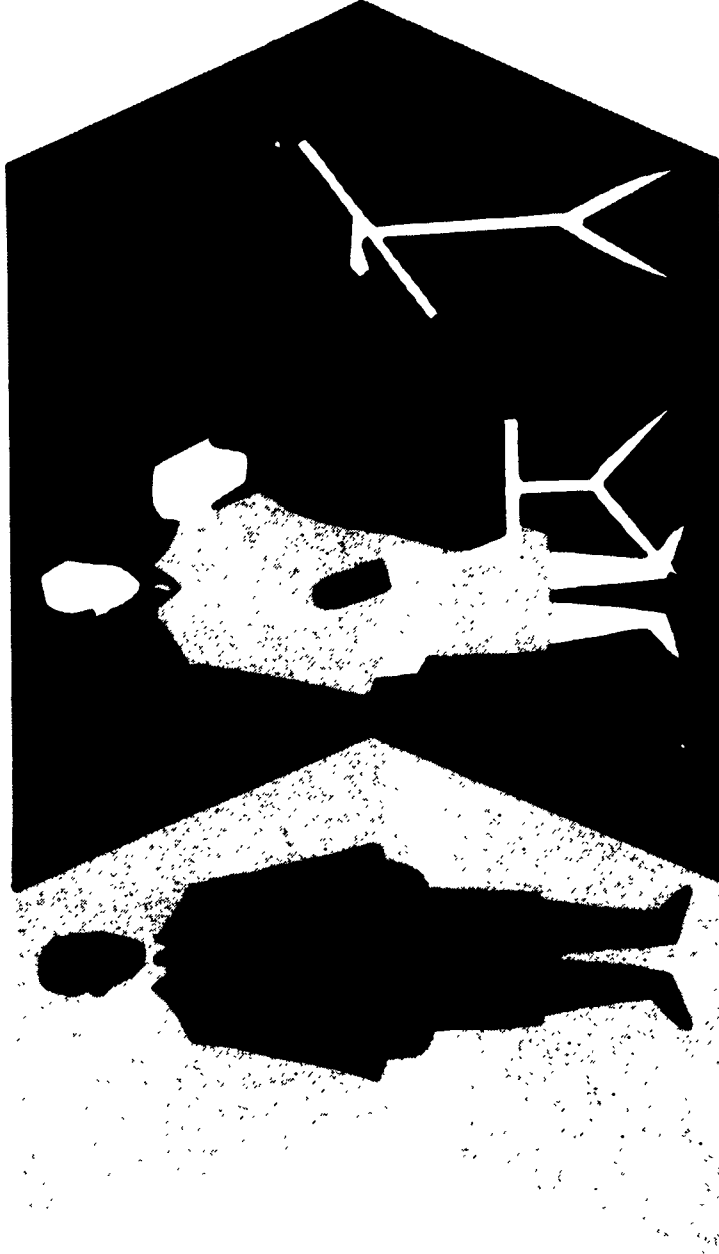

To the architect, it provides a concise and definite statement of the school's requirements—something he must have to design a building which is not only handsome but functional and flexible, pleasant and healthful to work in, and economically sound. He will use the program from the moment he begins his preliminary sketches until he completes his final design, and it will continue to serve as a yardstick for measuring all later modifications.

For the educator, too, programming is of great value. It is a chance to analyze thoroughly the implications of a changing philosophy of dental education and to plan a school adaptable both to current needs and future possibilities.

To define objectives, committee members must decide whether the school will concentrate principally upon undergraduate education or include graduate work, for example,

and whether particular emphasis should be given research. To outline the types and amounts of facilities required for each activity, the members must consider how teaching methods, as well as the subject matter taught, how the size and make-up of the faculty, as well as the student enrollment, affect space needs and arrangements. By preparing preliminary cost estimates in programming, committee members avoid last minute, ill-considered compromises by scaling their enthusiasm at an early stage to a realistic budget. In short, programming reduces the risk of long-range planning and enhances its ultimate value. The small but vital detail, too often overlooked under deadline pressure, is permanently listed. Larger, more prominent considerations are placed in context and perspective.



STAFFING A PLANNING COMMITTEE

Because all later stages of planning rest upon the educational goals outlined in programming, the dean of a school should be appointed early enough to assume, from the beginning, direction of programming as well as the chairmanship of the planning committee.

The members of the committee should include department heads, if they have been named, or other persons experienced in programming and well informed about dental education. The roster should be reinforced by specialists from fields such as administration and budgeting. In later stages of programming, when technical problems increase, either the school architect or a consulting architect should be called upon for advice.

FURTHER SOURCES OF INFORMATION AND ADVICE

Utilization of the resources of college or university bureaus of institutional research, trips to other schools, interviews with authorities in allied fields, a careful study of available educational and architectural literature—will reduce the dangers of shortsighted and uninformed decisions that lead to inflexibility in school design.

The main ingredients of good programming, however, will be the wisdom and vision of the committee members—their knowledge of dental education, their willingness to forego individual personal preferences in favor of more comprehensive solutions, their ability to think of long-range values rather than a quick return.

RESPONSIBILITIES OVER THE LONG HAUL

After the program is completed and the architect's schematic drawings have been accepted by the committee, the architect must undertake the series of architectural studies which provides the basis for his final design. The committee must stand ready to interpret the program, to advise the architect about any specific problems and, when necessary, to modify details of their program or to demand modifications in the architect's design and specifications.

During design and construction, questions will arise about building materials, provisions for such facilities as air conditioning, and, finally, equipment for the various laboratories and clinics. Although many of these are technical problems to be resolved by specialists, decisions which will materially affect either the ability of the school to function effectively or construction costs must be made by the planning committee.

STAFFING

Because departmental staffing plans will affect space and facility requirements, these will be established in programming. New schools will be wise to allow a year for the recruitment of professional personnel, however. As department heads and other key staff members should be in residence a

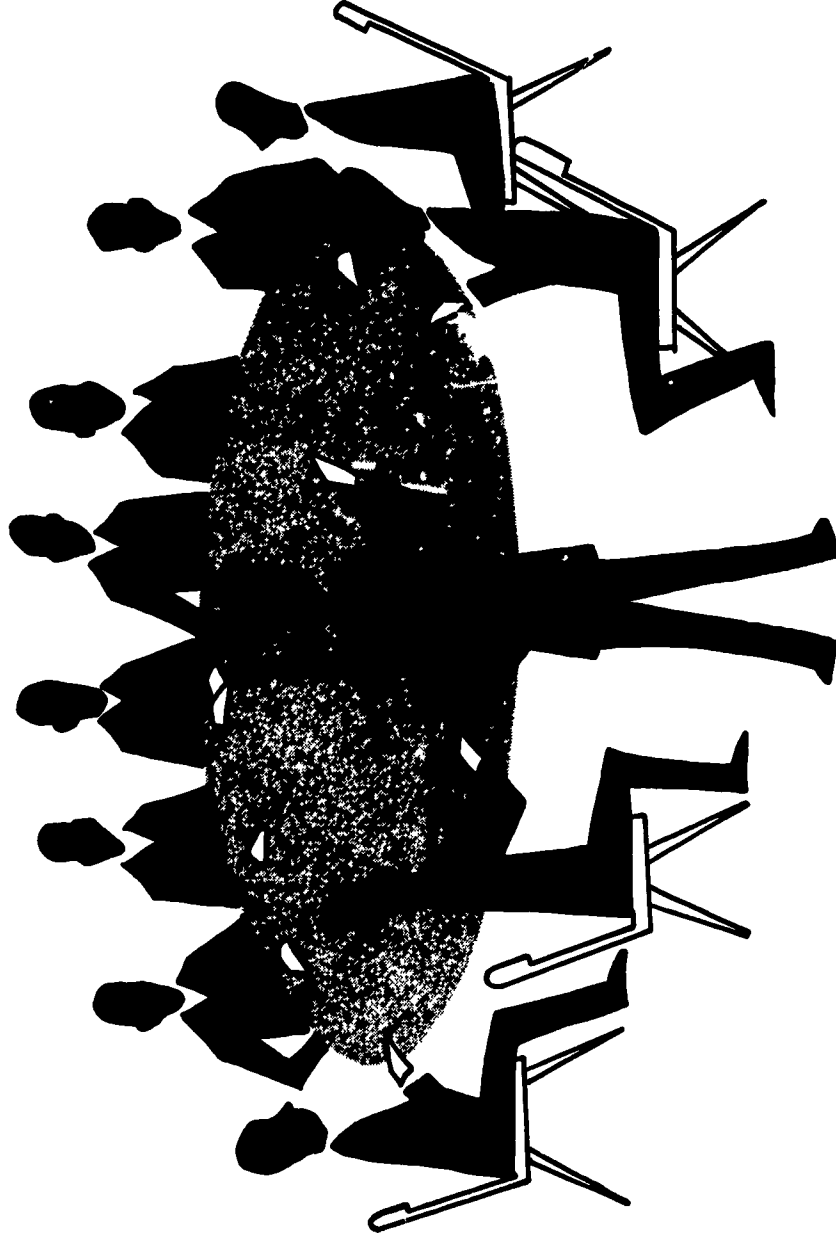

3 DEFINING OBJECTIVES

The programming committee's definition of objectives must cover three broad categories of dental school activity. One is the basic educational program, which includes not only the undergraduate curriculum but also graduate and postgraduate education and continuation courses for practicing dentists. A second category is research, basic and applied. The third is service.

Though these three categories are common to all dental schools, the emphasis given them varies from school to school. And within any one category, individual schools do not use the same methods in reaching identical goals. Yet, for all the differences that exist, some identifiable trends are beginning to emerge.

NEW PATTERNS IN DENTAL EDUCATION

Traditionally, dental school activities have revolved around the particular needs of the undergraduate student. Graduate and postgraduate studies have been of peripheral concern. Continuation courses, when offered at all, have usually been given at the convenience of the school, with little effort toward standardizing or systemizing them. Research activities have been minimal and service activities largely a by-product of undergraduate clinical training. During the years since World War II, however, this pattern has been significantly altered.

The growing demand for teachers of dentistry, and dentists schooled in research and in dental public health, the trend toward greater specialization, as well as the increasing desire of practicing dentists for instruction in new treatment and practice techniques, have reinforced the educators' grow-

year before the school opens, recruitment probably should begin soon after construction contracts are let.

The programming, designing, and equipping of a dental school is a time-consuming process, requiring approximately 3 years. Allowing 6 months for programming and at least 2 years for design, construction and equipping, the school initiated in 1963 will probably not admit its first freshman class before 1966. Therefore, it will graduate its first dentists no sooner than 1970.

This timetable underscores, as nothing else can, a very important point—planning committees are indeed planning for the future.

ing conviction that stronger, better organized programs of advanced education are essential.

GROWTH IN GRADUATE STUDIES

To the extent that their facilities and resources permit, the majority of dental schools are responding to these new demands. Graduate and postgraduate programs have grown in number, scope, and depth. At the same time, schools have intensified efforts to provide continuation training for practicing dentists. In 1960, there were 650 dentists enrolled for graduate study and another 650 in postgraduate programs. In addition, almost 7,500 practicing dentists were taking shorter courses to keep abreast of scientific developments.

Yet, few schools have been able to develop the programs of advanced study they desire. Many schools, housed in outdated and inadequate facilities, have been forced to improvise accommodations; others have been unable to provide them at all. As a result, most schools now plan construction which will permit them either to initiate new programs of advanced study or to strengthen those they now offer.

Even with such expansion, however, a large number of today's schools will still lack sufficient facilities to house adequate programs for the advanced student. Their experience suggests that any new school will be obsolete before the first students enroll if its planning committee has failed to include a balanced program of advanced study among its objectives.

THE INCREASING EMPHASIS ON RESEARCH

Existing schools have attempted also to place greater emphasis on research, which educators generally agree is essential for effective programs of graduate study.

Research on anything approaching a broad scale is a fairly recent development. As late as 1950, the average school budgeted only \$5,000 a year for research. Now, the average school spends close to \$100,000 annually, and some schools \$250,000 or more. Although this is a very modest rate of expenditure—(the average medical school, for example, spends nearly \$1.5 million annually on research)—all

schools now have active research programs, and well over half have also set up centers to train research personnel in the basic and clinical sciences.

But in research, as in advanced study, dental educators still consider existing programs inadequate. And here again, the new school can profit from the experience of existing schools—by planning, from the start, facilities which will accommodate, even stimulate dental research.

A BROADER BASE FOR SERVICE ACTIVITIES

Service activities are not only growing, but changing. Once the services a dental school offered its community were simply those incidental to the school's need for patients in its teaching clinics. Today, however, an increased student interest in dental internships—plus more opportunities to intern—and the imminent expansion of hospital dental practice are signs pointing the direction in which future service activities will move.

Other new service activities include those designed to find means of providing care to groups, such as the chronically ill, the aged, and the mentally ill, who cannot be served within the traditional pattern of dental practice. Some schools are already offering special training in the treatment of these patients; others will follow suit.

TRADITION AND ALTERATIONS IN UNDERGRADUATE EDUCATION

The undergraduate dental curriculum encompasses both the basic biological sciences and the dental sciences. Traditionally, the basic science courses are concentrated in the freshman and sophomore years. During this same period, the preclinical dental sciences are introduced. Commonly, the student spends half of his school day in the basic science departments, attending lectures and conducting experiments which further his knowledge of the structure and functioning of the human body, and of the diseases which attack it. The second half of his day is spent in the preclinical dental science laboratories, where he learns, by practicing upon models, the rudimentary skills of dental treatment.

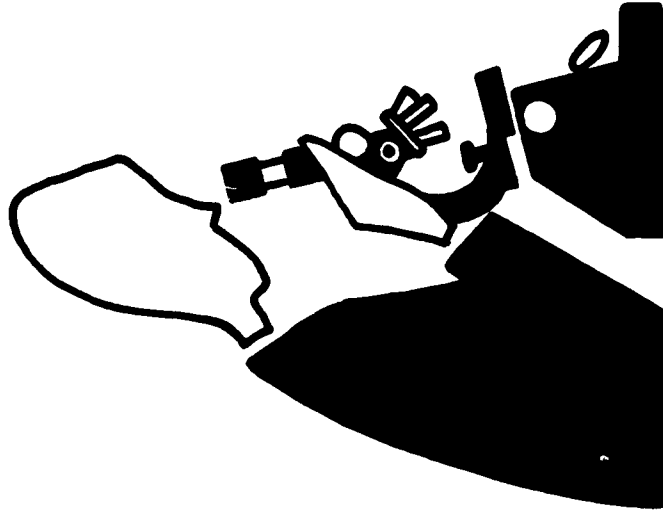

In his junior and senior years, the student spends the bulk of his time in the school clinics, where, under the supervision of his instructors, he treats patients with various oral diseases and disorders.

Even today, variations in the established curriculum are unusual, though differences in emphasis exist. For example, the number of clock hours dental schools devote to clinical orthodontics ranges from 20 to 240; the number given to general and oral pathology ranges from 130 to 400. But whatever the emphasis, today's student devotes his time almost exclusively to those courses and skills related to the practice of restorative dentistry.

Innovations in the Undergraduate Curriculum

Although experimentation has been limited, dental schools, aware of the new demands being placed upon their graduates, have begun to introduce some promising changes in undergraduate study.

The use of chairside assistants—one innovation already introduced—promises to give the schools some of the leeway they must have to add new courses and try new approaches in teaching.

Nearly all dental schools now offer formal undergraduate training in the effective use of chairside assistants. Working with the assistant, the student learns to delegate to her many of the routine tasks which he now spends a considerable time in mastering. In the future, dental schools may be able to give these routine procedures less emphasis, and the time saved in undergraduate training can be put to a different and more valuable use.

Should New Courses be Added?

Educators are therefore seriously considering expansion of the undergraduate curriculum. Most of them stress the importance of special emphasis upon preventive dentistry; they consider the addition of comprehensive courses in practice management essential. Many would like to see courses in the social sciences, which have developed tools and techniques with a direct application to dentistry, expanded.

Obviously, any dental student with even a background knowledge of these fields will be better prepared to assess and act upon issues which affect his professional and social responsibilities. Students more thoroughly trained may find careers in areas which did not until recently exist.

New Modes in Teaching

One teaching innovation almost certain to become increasingly influential is educational television. Still in a developmental stage in all branches of higher learning, and as yet unavailable in many dental schools, ETV has nonetheless impressed educators and scientists alike as a teaching aid of great potential effectiveness and adaptability.

The use of TV in operatories and laboratories is already far enough advanced to suggest that it will have great impact on the teaching of the health sciences. Used in the operator, ETV affords the student a much closer view of the operative field, permitting him to see in detail what was before visible only to the surgeons themselves.

Now, with the refinement of techniques in TV microscopy, it is apparent that the implications of television for all of professional education have only begun to be realized.

Several other trends are gaining momentum. One is the very definite movement toward small group instruction. Generally regarded as being more effective than the more usual large group method, it offers more intensive and thorough subject coverage and permits the grouping of students according to learning abilities and progress.

In laboratory work, it is becoming increasingly common to set up separate experiments and rotate small groups of students from one special project to another. This special project teaching allows more individual instruction and gives the student greater opportunity for independent inquiry than does the routine following of a prescribed series of experiments.

Small group teaching has stimulated another, closely related trend in undergraduate basic science training—integrated teaching. Instruction is given not in specific disciplines, one at a time, but concurrently in related disciplines,

with study and experiment focused on the various biological systems.

The Coordination of Basic and Clinical Instruction

Perhaps the most significant of the innovations in undergraduate education are efforts to achieve an interlocking of scientific and clinical training. Many educators and practitioners believe that the time gap which ordinarily exists between clinical instruction and the rest of the undergraduate curriculum is detrimental to the student's development as scientist and as clinician. He overlooks the practical application and interrelation of scientific knowledge and theory to clinical practice. And he frequently regards basic science courses as little more than an annoying delay to the beginning of clinical practice.

To offset the intellectual separation which can result from divided training, some schools are introducing students to clinical instruction at a much earlier stage—usually in the sophomore year when basic science studies receive their greatest emphasis. Others are extending basic science instruction into the junior and senior years. A stronger effort is also being made to correlate the content of basic science courses to clinical dentistry.

Because concurrent and correlated training gives the student a far better understanding of the interdependence of the basic and dental sciences, he becomes potentially a more capable clinician and a better acclimatized scientist.

The Basic Sciences: A Question of Jurisdiction

There is one major question with regard to the basic sciences over which dental educators disagree—whether or not a dental school should have its own basic science department. Many dental schools not only lack their own basic science departments but have little authority over those they share with other schools.

In these schools, basic sciences are taught and basic science departments are administered and controlled by some other school within the university—usually the medical school or, sometimes, the basic science department. The sharing of

basic science facilities has worked out well in some dental schools; it has proved unsatisfactory in others. Those who believe that the lack of their own basic science department is a handicap to dental education cite several reasons for their stand:

Dental school requirements are not given their due weight by other instructors. Research activities are almost never focused on dental problems—a factor which may contribute to the sparsity of dental school research.

Further, the dental school cannot sufficiently control either the size and make-up of the basic science faculty or the content of individual courses.

Finally, the dental school cannot guarantee to its most capable graduates the opportunity to undertake advanced study in basic science areas of critical concern to dentistry.

Although such problems do not exist in great frequency today, dental educators, if given a choice in the administrative pattern for a new school, often recommend that dental schools contain their own basic science departments. The newer pattern of the university medical or health center, in which a vice-president serves as coordinator for all health profession education, appears to provide another solution for harmonizing the separate interests of medical, dental, pharmacy and nursing schools so that no one discipline dominates the others.

OBJECTIVES: A GOOD DEFINITION MUST ENCOMPASS CHANGE

That today's dental educators are so deeply aware of the need not only for more width and depth in what they teach but for greater effectiveness in the way they teach it is one measure of the responsibility which planners of new schools must shoulder. Obviously, the definition of a dental school's objectives is not only the first of the programming committee's duties; it is also the most important. The definition cannot be limited simply to a restatement of existing educational goals. The professional role of the dentist is changing, and inevitably dental education is changing with it. The committee must encompass change within its definition.

4 OUTLINING NEEDED FACILITIES

The outlining of a school's physical facilities, the second step in programming, is undertaken only when the planning committee has written its formal definition of objectives. It is completed only when every proposed physical area of the school has been catalogued, its dimensions estimated, its nature, purpose, and functional relationship to other areas of the school described, and every required special feature itemized—all in sufficient detail and with enough precision to allow the architect to proceed to the preliminary design.

This study, if objectively and carefully done, should guarantee physical facilities which accurately reflect the degree of emphasis on teaching, research, and service envisioned in the statement of objectives and permit the school to reach its goals in each activity.

ACTIVITIES DETERMINE FACILITY REQUIREMENTS

The sequence in which space planning takes place is extremely important. Even for the most experienced educator, space planning properly begins, not with a listing of facility needs, but rather with a listing of the activities for which facilities are needed. It then proceeds to an identification of needed facilities for each activity, describing them carefully enough to permit a summary of amounts of space needed for fulfilling carefully specified functions.

The temptation to reverse this order—to define the facilities the school will need and then fit the program to them—should be resisted, for the particular space needs of specific activities can too easily be overlooked. Remedying such oversights is almost always costly and frequently impossible.

Actually, the committee will find itself undertaking a series of preliminary investigations as a basis for the many decisions required at this stage of programming. Whether it is desirable or feasible to set aside space for the exclusive use of any one activity, whether allocations of space need to provide for an entire class or for only a segment of it, whether, and to what extent, space allocations should allow for future expansion—all these, and more, are decisions which must be made for each individual activity. Once these decisions have been made for all activities, the total picture of the school's space needs will be brought into focus.

UNDERGRADUATE FACILITIES CONSIDERED FIRST

Although data for the different programs may be compiled in any sequence, the analysis of space needs should begin with the undergraduate program, since the facilities used in this program are so closely interrelated with those of every other activity. Before undergraduate space needs can be estimated with a reasonable degree of accuracy, the specific content of the undergraduate curriculum and the teaching methods for each course will have to be determined.

In addition, the departmental structure needs to be worked out, staffing patterns established, and faculty to student ratios set for classroom, laboratory, and clinic instruction. Only then should the committee proceed to the actual working out of undergraduate space requirements.

Once again, the safest approach is to proceed systematically, listing, discipline by discipline, the activities to be undertaken and describing the major characteristics of the space for each activity—whether it is laboratory, classroom, clinic, or seminar space. A preliminary summary by types of space will provide leads to the possibilities for the joint use of facilities and the scheduling of classes. This part of programming can be considerably simplified by planning for an entering class of a size which is a multiple of 16.

THE 16-STUDENT PLANNING UNIT

A module, or planning unit, of 16 is recommended because in so many of the basic and clinical sciences 16 students, or some division of 16, constitute a group of optimum teaching size.

Ratios of 16 students to 1 faculty member are feasible in many basic science disciplines, and ratios of 8 to 1 and 4 to 1 are frequently used for clinical instruction. Demonstrations are also often planned for groups of four.

Other modifications of these ratios can be used, of course, and where experience has shown that adequate supervision and a high level of instruction can be maintained for larger groups, two or more units of 16 may be combined.

TWO WAYS OF EXPRESSING SPACE ALLOWANCES

By Student Position—Although use of the student module will aid the committee in determining the number of students to be accommodated at any one time in space of a given type, this number will, of course, differ from one area to another and, for the same type of area, will vary from school to school. Therefore, in this volume, space allowances for student accommodations are frequently expressed not only in terms of the 16-student module but also in terms of the amount of space required for each occupant (the student position).

By Entering Class Student—Where space requirements vary with total enrollment, space allowances are often expressed in terms of the entering class student (ECS). But however they are expressed, all space allowances are rough, yet generous enough to allow a certain measure of flexibility in final design.

THE UTILIZATION FACTOR

Once preliminary space allocations have been made, every area of undergraduate instruction should be assigned a utilization factor which defines the relationship between the

UNITS OF 16 MAKE FOR EASIER PLANNING

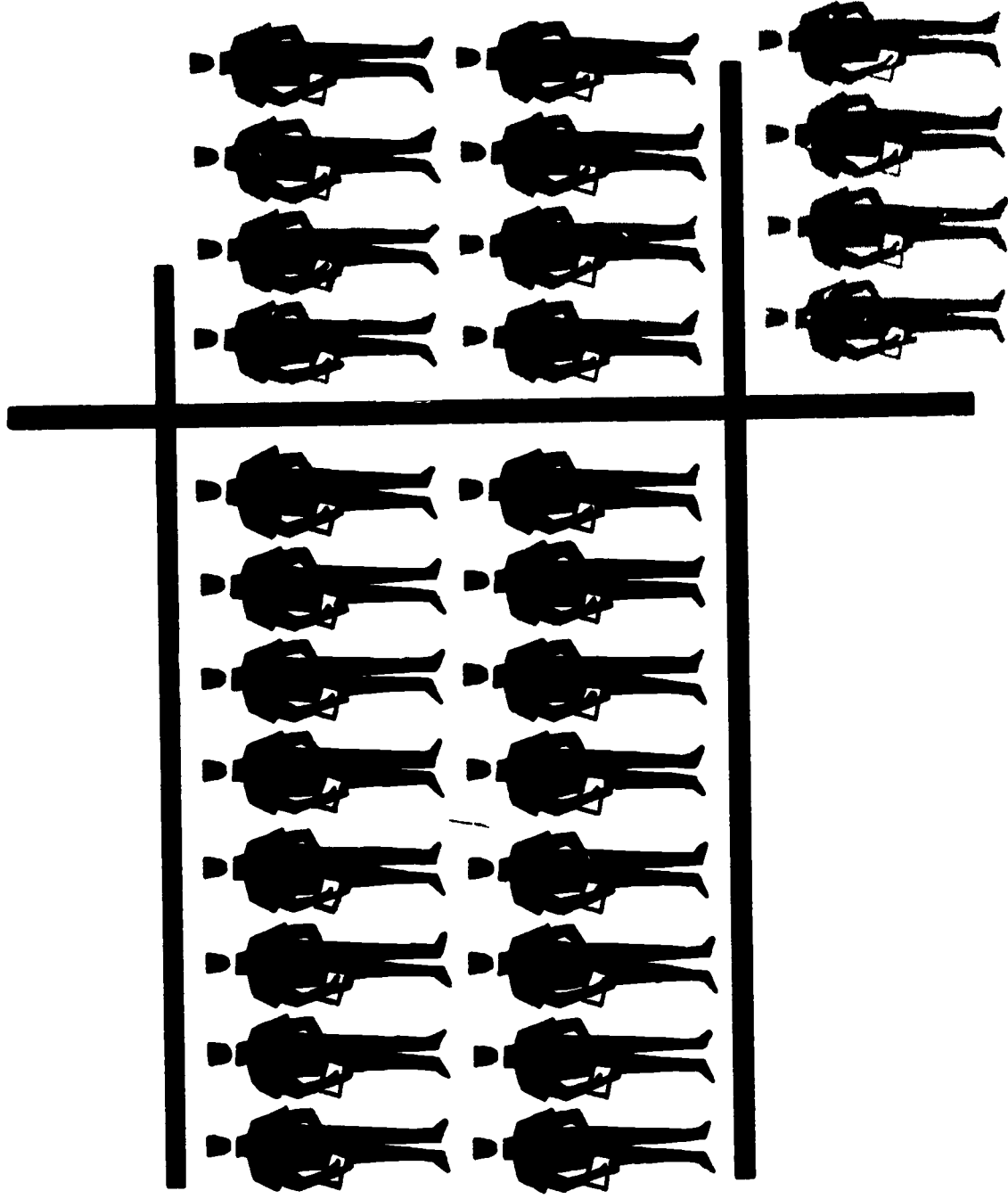

amount of use actually planned for the area and the optimum potential use. Both the time available for occupancy and the capacity of the area should be weighed. If 48 hours is regarded as the time available for occupancy, for example, a departmental teaching laboratory to which students are scheduled for two sessions of 3 hours each (6 hours per week) would have a utilization factor of 12.5 percent, provided that this were the laboratory's only use. A lecture room occupied for 24 hours a week, but only half filled, would have a utilization factor of 25 percent.

While a high utilization factor normally indicates efficient use of an area, a low utilization factor does not mean that the area is necessarily destined for inefficient use. Unscheduled but necessary work should not be overlooked. Unscheduled occupancy is especially common in laboratory areas, where experiments often run beyond scheduled sessions or require additional time for preparation and dismantling—time that must be considered when evaluating a seemingly low utilization factor.

INFLEXIBILITY IS UNECONOMICAL

Though a low utilization factor should certainly be a caution signal, it does not mean that the area should be automatically eliminated. When space is shared for the sole purpose of achieving higher utilization, over-all efficiency rarely increases proportionately, for the problems of administration, staffing, scheduling, and maintenance are also increased.

Actually, too-tight scheduling may eliminate any opportunity for shared use by graduate students and others; separate facilities will then have to be added if other programs are to be adequately housed. The greatest danger in tight scheduling, is, of course, that it will prove a poor economy, permitting no expansion in either curriculum or enrollment, and allowing no opportunity to introduce new methods or programs.

5 ESTIMATING COSTS

Because the amount of funds available controls the extent and type of facilities in a building project, a third—and integral—part of the written building program is the presentation of preliminary estimates of cost.

For some schools, the ultimate design must be determined within a fixed budget, with educational, service, and research facilities tailored to fit. For others, the budget will be determined by the facilities decided upon. In either case, the first estimates of cost should relate to the facilities needed to reach the desired objectives. If a committee must develop the school's program around a predetermined building budget, this preliminary estimate of cost will be the basis for a reevaluation of the proposed facility and any necessary modifications in program plans.

NET AND GROSS AREAS

Once the programming committee has completed its analysis of facility needs, it will have an estimate of the square feet of space needed for the clinics, laboratories, classrooms, faculty and administrative offices, and other school components. This is the usable space or, in building terminology, the net area of the school. Before estimating costs, however, the committee must arrive at an estimate of the total square footage of the building—the gross area. It includes the net area plus allowances for such items as corridors, elevator shafts, and stairways; for the space occupied by walls, partitions, and columns; and for areas such as boiler rooms, which house mechanical equipment not accounted for in the written building program.

Although the ratio of net floor area to gross area varies with the type of construction, structural design, and me-

chanical equipment, the maximum amount of usable space that can be expected in a dental school building is approximately 65 percent of the gross. This figure can be used to convert the estimate of net area into an estimate of gross square feet. (Simply divide the net square footage by 65 and multiply by 100.)

Having established the total number of square feet needed the committee will then be ready to prepare its preliminary estimate of the cost of constructing the building.

FOOTAGE TRANSLATED INTO COSTS

Only in rare instances will it be possible to base this estimate on local cost experience, since it is unlikely that there will have been a building project within the area comparable to a dental school. In the absence of applicable local data, the committee may base its estimate on the cost experience of dental schools built recently in other areas.

Cost indexes published periodically by the *Engineering News-Record* make it possible to construct an estimate of the average cost of constructing these schools, allowing for differences in the date of construction and their differences in location. This average can in turn be converted to current construction dollars for a specific geographic area.

The indexes only adjust for differences in wage rates and material costs, however, and do not reflect cost differences arising from other factors.

The degree of competition among builders and the relative availability of building materials are among the factors which affect the general level of costs in a given area, although they are not reflected in the indexes. And for a particular building project, costs are also influenced by the type of construction employed, by the efficiency of the contractor and those he employs, and, in an industry as seasonal as construction,

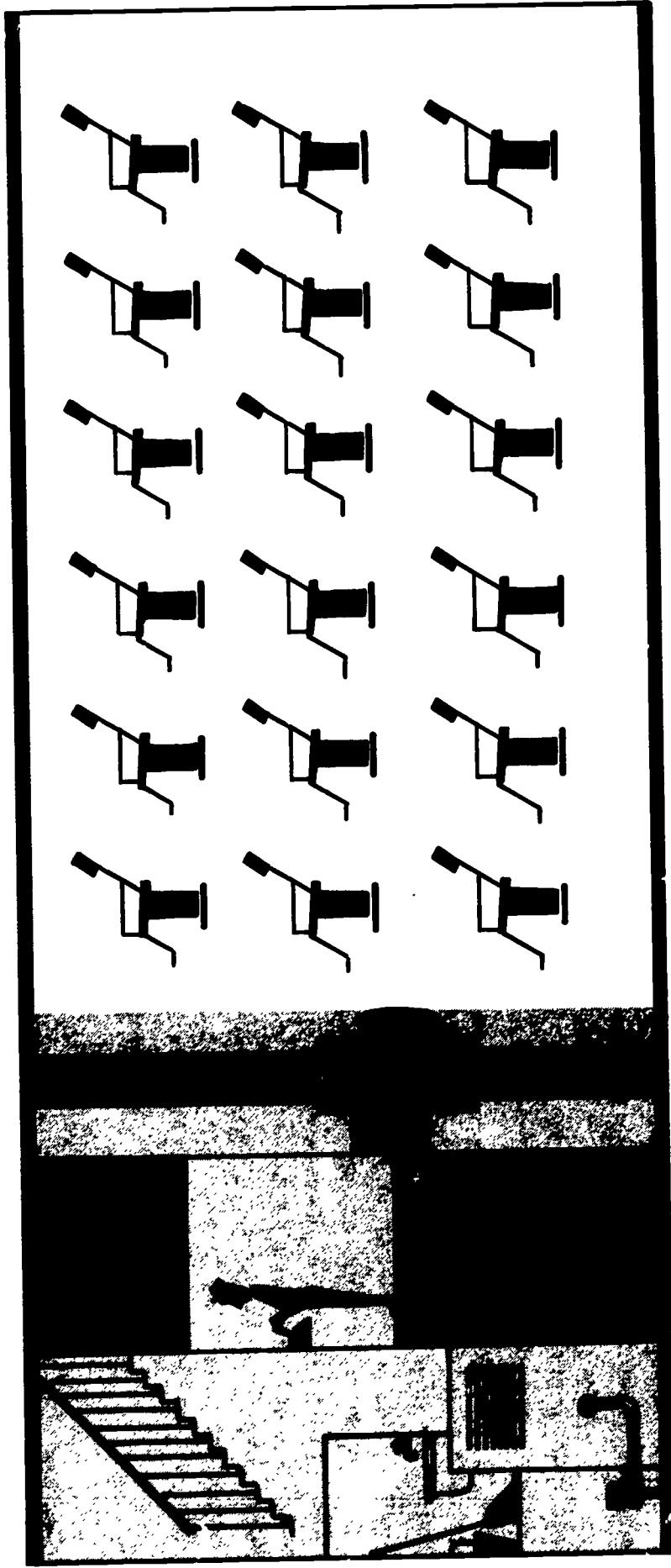

even by the timing of the bid-letting procedure. For these reasons, the committee, before using any cost figure derived by adjusting this average figure, should make sure that it has been reviewed by an architect who is aware of local building conditions.

Table I shows the wide variation that exists in the cost of dental school construction, based upon the experience of ten recently completed building projects. Adjusted to a common geographic standard and expressed in 1962 dollars, the costs of these new facilities range from \$20 to almost \$45 per square foot for individual schools. The average cost of construction for all schools is \$30 per square foot.

This average covers only the actual cost of construction. It does not include the purchase of the site or the expenses of site improvement. Nor does it cover the cost of equipment. Architectural and other fees are also excluded. Altogether, added expenditures such as these consume a substantial portion of any building budget.

In one recently built school, \$400,000 out of every \$1,000,000 spent was needed to cover these extra expenses, leaving only \$600,000 for the actual construction of the building. (Table 2). And since only about 65 percent of a dental school building is net area, less than \$400,000 out of every million dollars was available to this school for housing its educational, research, and service activities.

There is no exact and universal formula for estimating expenditures of this type, but because they account for so large a portion of the building budget, they must be included in any realistic cost assessment. Planning committees will therefore find it necessary to compile the data applicable to their own locality before proceeding with their preliminary estimates of cost.

COST FLUCTUATION

Planning committees must also recognize that construction costs fluctuate. Often two or three years elapse between the programming stage, in which preliminary estimates are made, and the letting of bids for construction. Whether building

costs will go up or down cannot be forecast for long periods, but certainly the long-term trend has been for costs to rise, and budget allowances should be made for possible increases. Normally these do not exceed 3 percent per year, and this figure is adequate for preliminary programming.

Equipment costs also fluctuate, and sometimes drastically within short periods, when designs are changed or new equipment developed. The fluctuation allowance for equipment should be even more generous than that for construction.

Project	Cost per square foot (1962 dollars)
A	20.00
B	22.00
C	24.00
D	26.00
E	28.00
F	30.00
G	32.00
H	34.00
I	36.00
J	38.00
K	40.00
L	42.00
M	44.00
N	45.00

INITIAL COST VS. MAINTENANCE COSTS

Low initial costs usually increase the possibility of high maintenance costs throughout the life of the structure. The fear of being criticized for extravagance by those not conversant with the dental educational program should not tempt planning committees to cut corners in quality. Compromises should not be accepted until their long-term effect on health, safety, maintenance, operation, and insurance costs has been carefully considered. Immediate building economics should, in fact, always be measured against future maintenance and operational costs.

REMODELING COSTS

Methods of estimating costs for new buildings do not apply to alterations. Although equipment costs may be similar, the square footage costs for remodeling cannot be standardized, as they can for new construction. So many variations occur in alteration or remodeling projects that it is necessary to figure separately each item of work, such as plumbing, air conditioning, electrical work, and structural work. Because remodeling sometimes costs more than new construction, the development of comparable cost estimates may help an existing dental school decide whether to enlarge its present facilities or to build an entirely new wing or building.

PERIODIC REVISION OF COST ESTIMATES

Estimates should be made as early as possible in the programming stage. They should be revised in the schematic drawing or diagrammatic sketch stage, and again in the preliminary drawing stage. This updating at every stage of planning will not only save time but will also forestall last minute revisions and reductions in the scope of the project.



OTHER PLANNING CONSIDERATIONS

- 6. SELECTING THE SITE**
- 7. THE PHYSICAL PLANT: DESIGN AND STRUCTURE**
- 8. WITHIN THE PHYSICAL PLANT: SPACE RELATIONSHIPS**

Part

6 SELECTING THE SITE

Within certain limits, the selection of a site for a dental school can be made at any time during the early stages of planning. However, the site selected will influence not only the architecture of the building but also the provision of certain facilities within the school. For that reason, the decision should probably not be delayed beyond the time when the programming committee has prepared its preliminary estimates of space and facilities requirements.

Whether those who program the school will also bear the responsibility for site selection is a decision for individual planning groups. Sometimes a special committee is appointed. But whatever the arrangement, few committees will have complete freedom of selection. Sometimes the exact site will have been predetermined. Sometimes their choice will be restricted either to selecting from among certain pre-designated sites, or to selecting a site at some prescribed general location.

To the extent of its mandate, however, the appropriate committee should examine all possible sites, and their recommendations should accompany the written building program. If the site has been predetermined, their report should include an evaluation of it and an estimate of expenditures required to eliminate any undesirable features.

PREFERRED LOCATIONS

Dental educators generally prefer certain locations for a dental school. The obvious choice, a university campus, has impressive advantages. It offers students and faculty a richer cultural life and often a more pleasant environment. Adequate housing and student facilities may be more readily

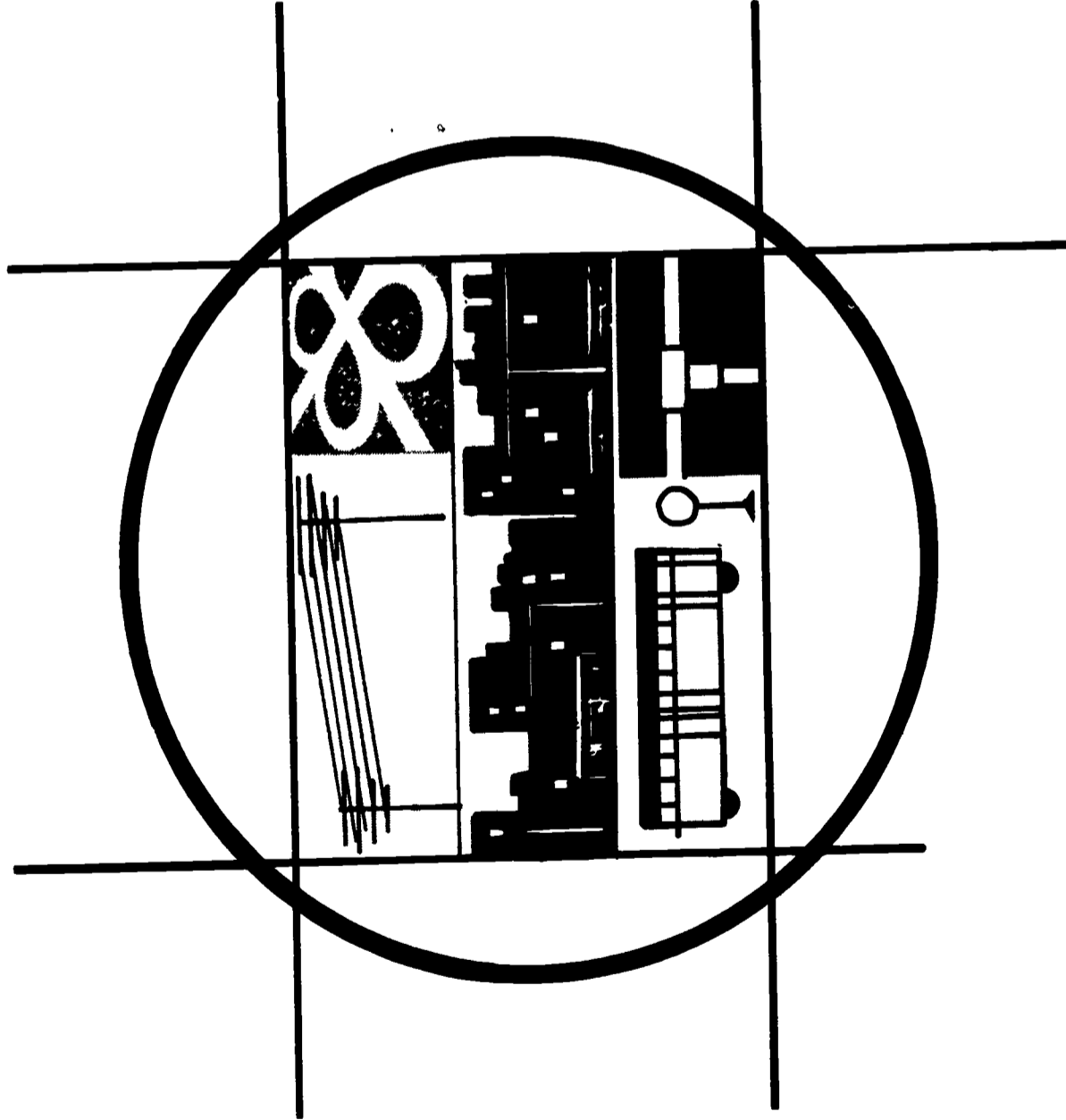

available than in other locations. If the university also has a medical school on campus, students and faculty can enjoy a close association with other health professions. Above all, the university campus offers the academic atmosphere which is both suitable and desirable for an educational institution.

Location in a health center is also advantageous, since it offers access to a complex of health facilities and provides day-to-day opportunity for close cooperation between the health professions. A metropolitan location generally assures the school an ample supply of patients for teaching clinics.

The ideal location would offer all these advantages, but few schools will be fortunate enough to have the problem of location resolved so satisfactorily. Most will have to settle for something less, and they will undoubtedly find that each possible location has disadvantages which must be weighed against its desirable qualities.

Locating on a university campus sometimes denies a school the close affiliation with a hospital which educators increasingly favor. The price of land in a metropolitan area may preclude purchase of a lot of really adequate size, or the lack of suitable housing in the immediate vicinity may be too difficult a problem to overcome. The relative importance of these factors, and others, should be assessed by the committee in selecting a general location.

THE SITE ITSELF

Once a general location is chosen, the committee must consider the merits of specific sites. In some instances, the general location automatically eliminates potentially serious difficulties. Sites in metropolitan areas, for example, seldom lack adequate utilities. As a rule, however, the committee must study thoroughly all the factors that make a site desirable or undesirable. Some major considerations are discussed below.

Topography and Dimensions.—High ground with natural drainage is desirable, but the elevation should not be so high that approach on foot is difficult. A patient entrance at ground level and a service drive to the basement area should

be feasible. A gently sloping lot has advantages, since it offers entrances on two levels; traffic in and out of the building is automatically divided between them, and the movement of people and supplies can more easily be diverted over separate routes within the building.

In areas where these are potential sources of trouble, the site should be checked for mineral rights, site undermining, fault lines, and other geological conditions.

The dimensions of the site selected will affect the floor plan adopted. Small sites in metropolitan areas will require multi-story buildings to provide necessary floor space. Zoning laws should be investigated to ascertain both the future character of the neighborhood and possible restrictions on the site under consideration. Regulations not only affect use of the buildings, but, in many cities, also limit the size of the building to a percentage of the total plot. Height is often regulated, as are parking and service areas. The site selected should be of sufficient size to permit later expansion.

Where land costs are favorable and where parking facilities are planned, a building site covering a minimum of 10 to 12 acres is advisable.

Utilities.—An engineering appraisal of public utilities is always part of a well-prepared site report. Sewerage, water, electricity, telephone, and gas must be available on the site or be extendible to it at reasonable cost. Utilities must also have adequate capacity. For instance, low water pressure may require booster pumps for upper floors of the proposed building. Sewer levels above the lowest floor level will entail the expense of ejector operation.

Transportation and Parking.—Convenient public transportation is a necessity. Runs should be frequent, with adequate peak-hour service. Good public transportation materially reduces the parking problem. It also makes it easier for the school to secure and retain service and clerical employees. Even with good public transportation, first-class roads should connect the school directly with local traffic arteries.

The site should permit adequate parking areas for students, faculty, and patients. Local ordinances should be studied, since they may require and define adequate parking facilities. Parking requirements are sometimes related to the square foot area of the building. The site's general location—urban or rural—whether it is on or off a university campus, its distance from student housing, regulations governing driving on campus, and the adequacy of public transportation will influence the amount of parking area needed.

Generally, one parking place for each full-time faculty member and one for every two part-time members is advisable. A site in a suburban area should also allow two parking places per ECS for students, if possible, and another two places per ECS for clinic patients.

In determining how much land will be needed for parking, allow 130 cars per acre (for 45-degree parking) as a guide if parking lots are to be used. Parking lots, however, are likely to become desirable building sites, and multilevel garages or underground parking may prove a more permanent solution to the parking problem.

Annoyances.—Objectionable noise, odors, smoke, or dust result in an undesirable environment. Correcting these nuisances is often not feasible and is always expensive.

The disturbance caused by aircraft is often overlooked when locating public buildings. Avoid a site immediately under the takeoff and landing paths of jet runways. In general, this area extends from 1/2 mile beyond the approach end of the runway to 2.8 miles beyond the takeoff end. In width it extends approximately 1/2 mile on either side.³ The Federal Aviation Agency can furnish information on present air routes and approach zones, as well as on proposed changes.

Since the school itself may be considered a nuisance by residential neighbors, good public relations demands the selection of a site which minimizes the possibility of the school's becoming an unwelcome neighbor. Sources of annoyance may include smoke from incinerators and boilers, fumes from exhaust ducts, animal noises, and exposure of service areas, dog runs, and dissection laboratories. For this

See references on p. 111.

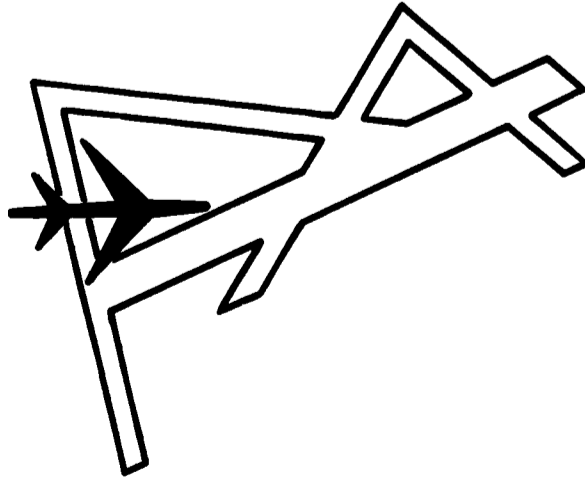

reason, it is wise to investigate the force and direction of prevailing winds and to make sure that unsightly areas can be adequately screened.

INITIAL COST NOT TOTAL COST

The initial cost of a site is not its total cost. Correcting the undesirable features of a donated site might prove so costly that the purchase of another site would actually be an economy. Among the additional expenses which may be incurred are charges for overcoming unsatisfactory drainage or subsoil conditions, for grading, for bringing in utilities from a distant point, or for title clearance.

In evaluating any site, the cost of eliminating undesirable features must always be weighed against the site's advantages.

7 THE PHYSICAL PLANT: DESIGN AND STRUCTURE

The physical plant must not only meet the specific demands of the written program, it must also represent an efficient utilization of space, permit flexibility in interior arrangements and economy in maintenance and operation, and, to the extent possible, allow later expansion or modification at a minimum cost and with minimum disruption.

MODULAR PLANNING FOR FLEXIBILITY AND EFFICIENT USE OF SPACE

One way in which architects assure a considerable degree of internal flexibility in a physical plant is by using modular planning. This method is particularly adaptable to the design of schools, hospitals, and other buildings in which repetitive elements lend themselves to the systematic and uniform spacing of certain structural features.

In modular design, large planning units, or modules, are used in the development of preliminary drawings. These units generally determine the spacing of walls, partitions, and columns. As a result, the interior is divided into uniform segments, which can be combined to form rooms of widths in increments of the selected module.

The size of the planning module is determined by the architect through an analysis of the design problem; it varies with different types of buildings. The module should be a multiple of the basic 4-inch module recommended by the American Standards Association Project A62.⁴

Many building components are prefabricated on this basis, and departure from the module may result in the additional expense of special fabrication. The floor plans in this book are based on modular design, using a module of 4'8".

In Laboratory and Office Planning

In the dental school, modular design is particularly applicable to the planning of research laboratories and offices. Figure 1 shows a section of a typical basic science laboratory, based on the 4'8" module. It is a two-module laboratory, approximately 9 feet in width. When allowances are made for the equipment and laboratory benches extending into the room from the wall, the two-module unit is the smallest size practical but yet adequate for its function. A room of narrower width would adversely affect function, a wider room would waste space and add nothing to the efficiency of operation.

Examples of Modular Planning

When modular planning of areas is combined with modular planning of utilities, various combinations of offices, laboratories, and storage space are practical. (See fig. 2.)

Figure 2B is a sectional drawing of a research floor of a school. Figure 2C is a partial plan of the corridor wall. Columns are located at every fifth module. Vertical utility shafts, which supply the laboratories with water, drainage, gas, and other utilities, are located at every fourth module. The partition here is called a wet wall. It is the point at

See references on p. 111.

BUILDING MODULE

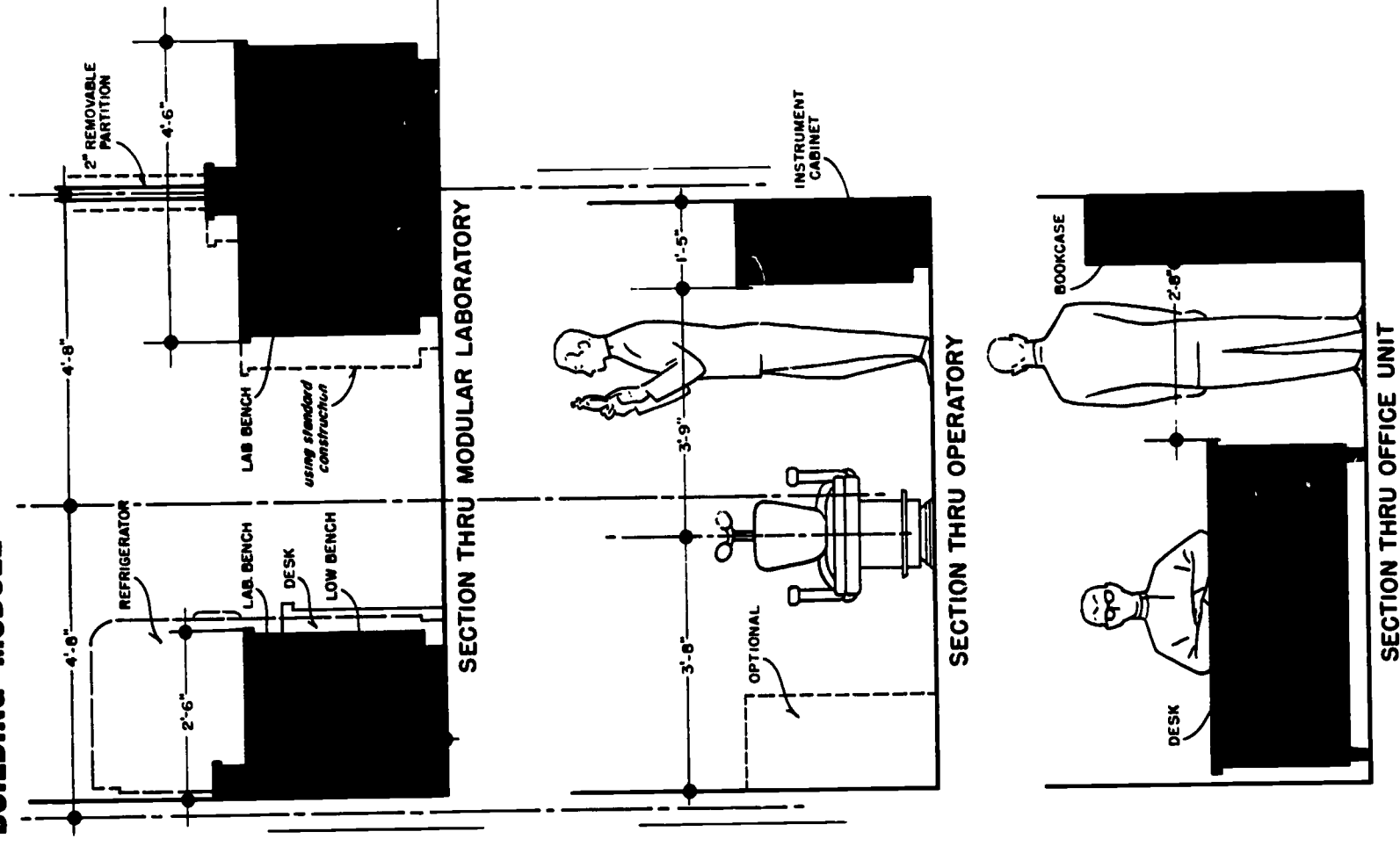
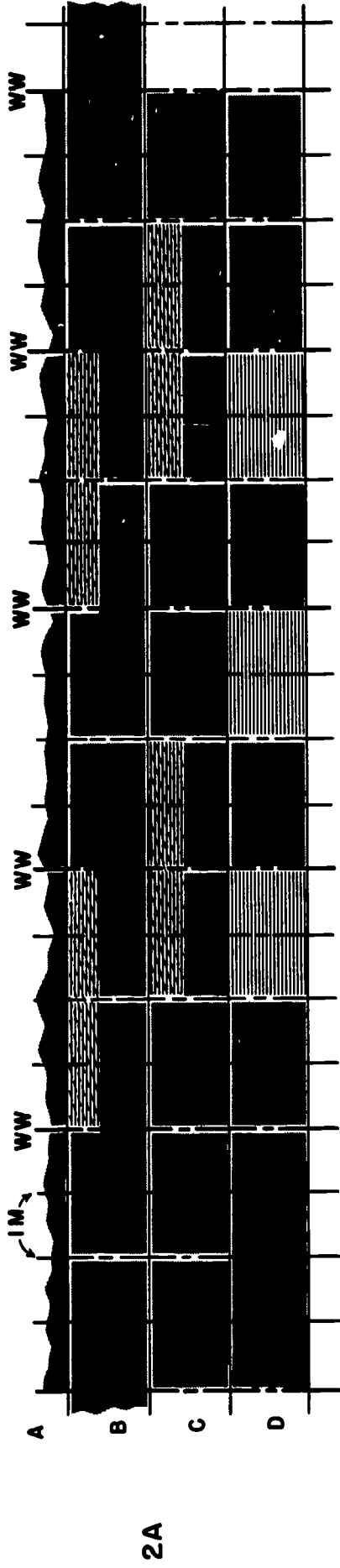

FIGURE 1.

MODULAR PLANNING OF RESEARCH AREAS



INDEX OF MODULAR USE

LEGEND

- M — Module
- Laboratory
- Office
- Office & Equipment Storage
- WW — Wet Wall — Utilities
- F — Fume Duct

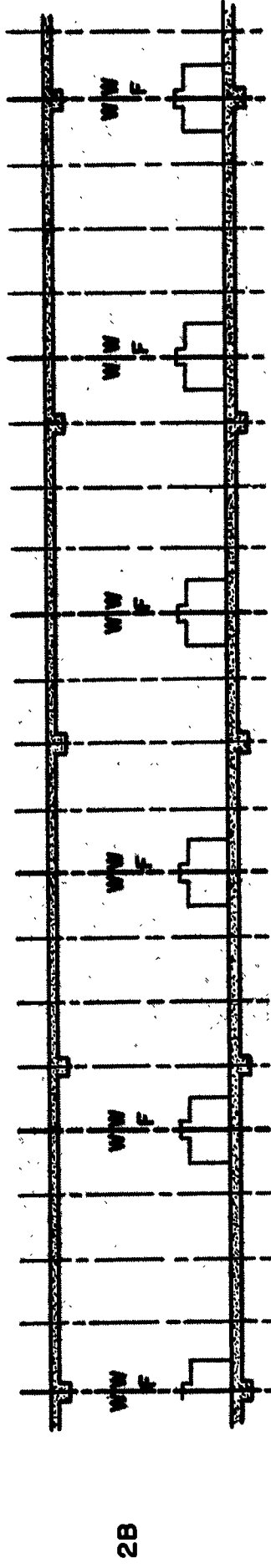

SECTION

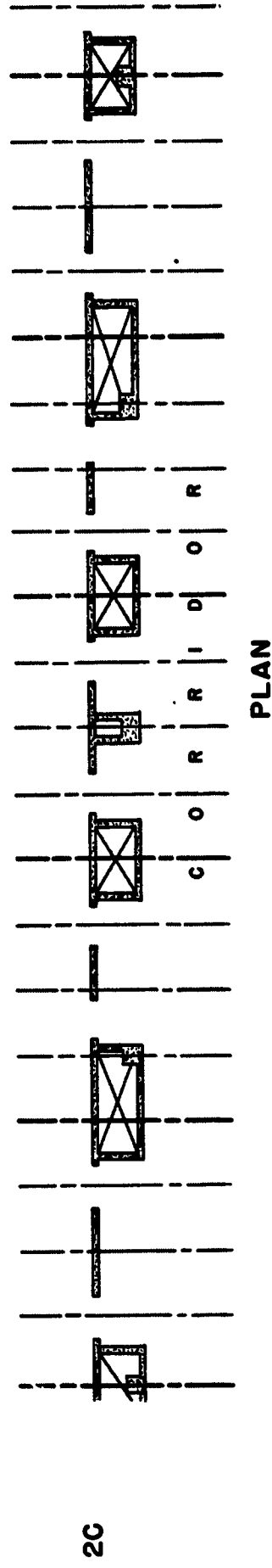

PLAN

FIGURE 2.

which utility branch lines can be carried from the vertical shafts. Partitions at other locations are dry walls and will not readily carry any utility except electricity.

Figure 2A shows the arrangements of laboratories, office, and equipment storage areas possible with this design. For example, if a series of laboratories of four-module width is desired, either index A or B can be followed. Index A has the laboratory bench at the side walls, while index B shows a center island or peninsula type of laboratory. If an office and equipment room is desired with each laboratory, these can be substituted for alternate laboratories.

Indexes C and D illustrate smaller laboratories suitable for one or two researchers. Index C is a series of laboratories only, and index D is a combination of two-module laboratories, offices, and equipment storage rooms. One or more four-module laboratories can easily be provided in combination with two-module laboratories.

Advantages and Limitations

Modular design can be applied to structures in which utilities are located at or in the exterior walls. It can also be used, and with perhaps greater flexibility, in research laboratories in which a central utility core is utilized (fig. 3).

Modular design provides a basis for determining the width of laboratories and offices. In estimating depth, at least 24 or 25 feet should be allowed. In figure 42, the bay depth is 28 feet—the equivalent of six modules; a sufficient allowance when utility shafts are located along the corridor wall.

Caution should be used in following modular planning for other elements of the dental school. Where location of columns is important, strict adherence to the selected planning module may result in obstacles in aisles and other areas. This is a particular problem in the clinics, where chair layout may be adversely affected by a lack of coordination with the structural and mechanical features of the building. In the clinic area, modular design is of lesser importance in those plans in which operatories, laboratories, offices, and other small rooms are not located along the exterior walls.

ECONOMY OF OPERATION AND MAINTENANCE

Building design and the choice of building materials affect maintenance and operational costs. Programming committees should therefore make certain that they have pointed out every specific activity which necessitates special materials or maintenance features. The architect can either choose among the alternatives available or advise the committee when they must choose.

No complete listing of these problems of detail is possible in this volume, but the following examples are offered as reminders.

The use of durable, waterproof floor and wall finishes is essential in the clinics and in many other areas of the school, and the written program should identify every such area. Certain sections of the building demand acoustical tile.

Similarly, several areas of the dental school—the anatomy dissection laboratory is one—should be air-conditioned, and, since dental schools are normally open during the summer months, perhaps the entire building should be. Many communities, by local ordinance, require that an engineer be on duty to attend heating plants and air conditioning equipment over a certain capacity. As only certain areas, such as coldrooms and constant-temperature rooms, may require 24-hour service, these might best be on independent systems.

The planning committee must decide whether any saving which is realized by air conditioning portions of the building, rather than the entire plant, will be great enough to justify the subsequent discomfort to student and faculty. Certainly the installation of air conditioning, or the inclusion of provisions for its later installation, is considerably cheaper when undertaken during construction rather than after the building is completed.

Installation of the cables and conduits needed for educational television systems can also be less expensive if undertaken during initial construction rather than at a later date.

Foresight in the layout of administration and reception areas is another way in which economies in operation and

PLAN FOR A BASIC SCIENCE AREA UTILIZING A CENTRAL UTILITY CORE

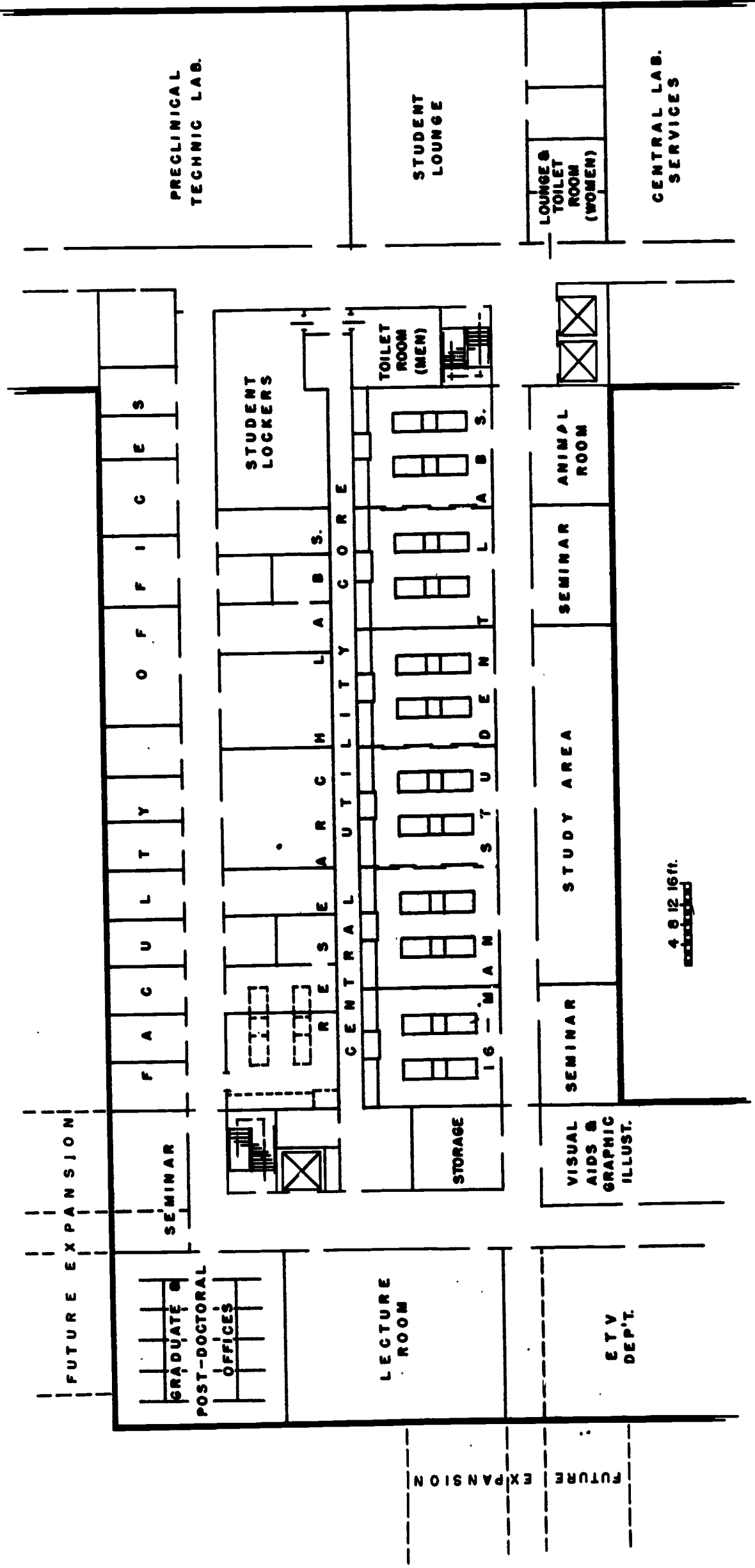

FIGURE 3.

maintenance can be effected—it permits reductions in staff requirements for years to come. For example, the installation of a telephone switchboard near the patients' entrance of a small school may permit the operator to double as information clerk. Centralizing patient reception and control at one entrance may eliminate the need for control at other entrances, and reduce personnel costs still further.

PLANNING FOR LATER EXPANSION

Even though planners believe that any future need to enlarge the school's enrollment or plant is unlikely to develop, experience nonetheless demonstrates the wisdom of a design which will facilitate expansion.

If the possibility of extending wings or adding floors has been anticipated in the initial building design, expansion can usually be achieved at less cost and less inconvenience.

Vertical growth can also be planned. Although it is common building practice to provide a foundation and other structural features which will allow the addition of new floors, these additions may still require costly modifications unless they are specifically anticipated in the initial design. Inadequate maintenance areas and utility systems prove especially troublesome, for example, when expansion is needed.

By the same token, supporting or ancillary facilities which are to be so located that their expansion may be difficult might better be sized from the start for maximum future use.

In substance, no point of concern is too large or too small to deserve attention from the programming committee. But because committee members will not always have a technical knowledge thorough enough to permit reliable decisions, they should consult with the architect before making them, and give careful consideration to his recommendations.

8 WITHIN THE PHYSICAL PLANT: SPACE RELATIONSHIPS

Teamwork between the dental educator and the architect is essential in the determination of space relationships. An effective, orderly arrangement of the laboratories, clinics, classrooms, offices, and other facilities which make up a dental school can be attained only when the architect fully understands the function of each element and its relationship to others. The educator must define and clarify function so that the architect, in his design, can place elements which have a functional relationship in physical proximity.

THE EFFECT OF TRAFFIC PATTERNS

The arrangement of the many elements of a school is determined largely by the movement of students, faculty, patients, and materials. Ideally, the facilities are arranged to reduce movement to a minimum.

Clinics.—The most common and effective way of reducing traffic within the school is by the physical separation of the clinical facilities from the remainder of the school. Staffed by a separate faculty and visited daily by large numbers of patients whose presence elsewhere in the school could be disruptive, the clinical facilities are logically a physical entity. For this reason, physical separation will continue to be advisable even though efforts to break down the rigid separation which exists between the clinical and basic science teaching programs are successful.

However, if they are successful, there probably will be a need to locate certain clinical areas so that students can move between the clinics and the basic science areas without disturbing the clinical routine. Planning committees should therefore consider the possible implications of this change for traffic patterns within the school.

Basic Science and Preclinical Laboratories.—There is less justification for preserving the traditional separation of the basic science and preclinical dental science teaching laboratory areas. This is not an arrangement based on logic, but rather one forced upon dental schools by the lack of their own basic science facilities.

The activities of freshmen and sophomores are largely confined to these areas: by locating them in reasonable proximity, with other facilities used by these students nearby, traffic within the school could be materially reduced. However, since laboratory sessions are normally scheduled for a full half day, with students shifting between laboratories only once a day, locating these areas on separate floors or in separate wings may well resolve a particular school's problems of space arrangement.

Determining Functional Relationships.—The architect, before proceeding to his preliminary design, must know not only the relationship of these broad categories of facilities to each other but also how the many individual areas which make up these categories relate to each other. Then he can make space arrangements and locate entrances and exits in a way which will minimize traffic within the school without disturbing function.

To study traffic patterns within the school and to work out appropriate compromises when two areas compete for the same location, the architect will prepare a series of space diagrams showing the relative relationship of the various activities. In these diagrams, locations are shown without regard to the exact amount of space individual activities require.

A DESIGN WHICH CONTROLS TRAFFIC FLOW

Figure 4 illustrates how effective planning reduces movement in a dental school. It is a space diagram showing the relationships between and within the clinical and preclinical dental science areas of a school which will locate its basic science facilities in another wing or on another floor.

SPACE RELATIONSHIPS: PRECLINICAL AND CLINICAL DENTAL SCIENCE AREAS

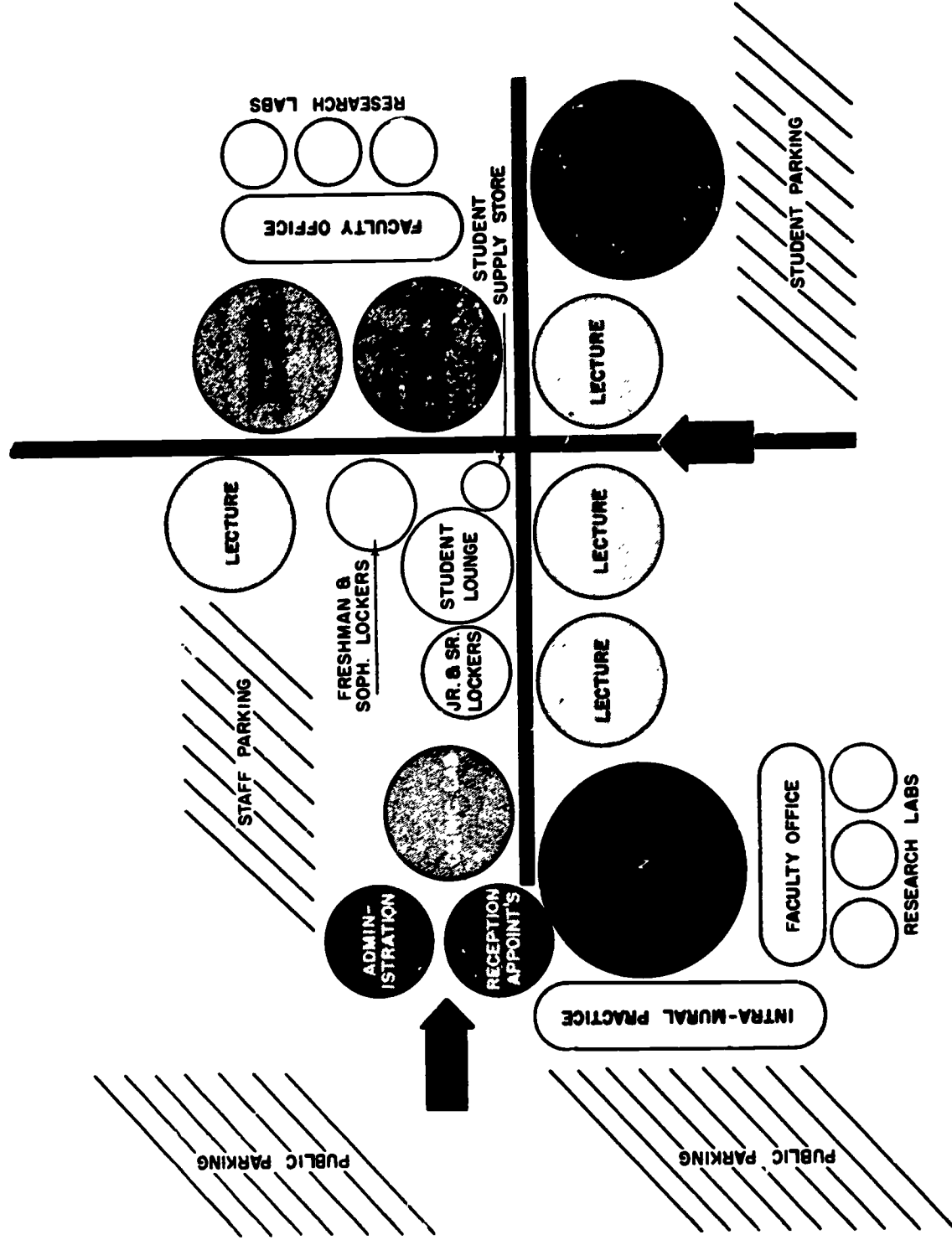

FIGURE 4.

All student facilities are located close to their major areas of activity. Note the proximity of student lounges and locker rooms to the teaching facilities used by the students. Freshmen and sophomore locker rooms are adjacent to the pre-clinical laboratories, while locker rooms for juniors and seniors are close to the clinic. Locker rooms for both groups adjoin the student lounge and book store and are located near the student entrance. Lecture rooms, used by both pre-clinical and clinical students, are readily accessible from all student areas.

RESOLVING COMPETING DEMANDS

No architect will find it possible to assign every element its ideal location; the functions of a dental school are simply too interrelated. Often, two different locations will seem desirable for one activity. Just as frequently, two different activities will compete for one location. In every instance, conflicts must be resolved in a way permitting maximum functional efficiency.

Sometimes conflicts resolve themselves. The nature of an activity or perhaps some special use being planned for a facility may make one particular relationship or one special location advisable, even though it rules out another

relationship which, under different circumstances, would be preferable.

The need for a location as free of vibration as possible makes the basement the preferred site for the electron microscope suite, for example, though this location is seldom convenient for users of the laboratory. Facilities which will be used after normal school hours—auditorium, libraries, and study areas—provide another example. Ideally, they should be located so that they can be left open after the remainder of the school is locked. In some schools, however, such a location can be attained only by overriding other reasonable claims for the same space.

Working together, the educator and the architect can resolve the most taxing problems of space relationships. The first step toward solution is, of course, the written program in which the educator describes fully both the function of each area and the functional relationship it bears to other areas.

Some of the space relationships which will be of particular concern in planning specific facilities are pointed out in the chapters which follow. In these chapters, planners of new schools will find both general guides and specific suggestions about the allocation and arrangement of space.

BASIC SCIENCE FACILITIES

9. BASIC SCIENCE FACILITIES—IN GENERAL

10. BASIC SCIENCE LABORATORY FACILITIES

Part

9 BASIC SCIENCE FACILITIES— IN GENERAL

Few decisions made in the initial stages of programming will have a greater influence on the space and structural requirements of the dental school than those reached in defining the school's teaching and research objectives in the basic sciences.

The school which elects to assume full responsibility for undergraduate basic science education will require not only teaching laboratories and the ancillary and special facilities associated with them, but also offices and adequate research laboratories for the basic science faculty and offices for the departments' administrative staffs.

Planning for several other areas of the school will also be affected. More lecture and seminar rooms will be needed. Larger animal quarters and technical shops and a more extensive visual aids department will be indicated.

Depending upon the research interests of the faculty, the school may also require sizeable amounts of space to house specialized laboratory equipment. If the school engages in an extensive research program, an office may be needed for a research coordinator. A program of advanced study means research and study areas for graduate students, ample seminars, space perhaps for added research equipment, and, very probably, accommodations for a larger faculty.

Some schools may prefer a compromise in the basic sciences. For example, one school may plan to assemble its own faculty, providing only offices for them, while relying on another school within the university for basic science teaching and research facilities. Or the dental school may provide the teaching and research facilities but rely on another school to supply the faculty. A more common arrangement is for a school to provide both faculty and facilities

for some basic science disciplines, but to rely completely on another of the university schools for the remaining disciplines.

However, unless a school offers no basic science teaching at all, it will require certain of the facilities discussed below.

DEPARTMENTAL FACILITIES

The head of every department needs a private office with space enough to accommodate small staff or student conferences. An adjoining office should be provided for the department secretary. A conference room, and a seminar room accommodating a 16-student group should also be provided. In addition to chalkboards and bookshelves, each room should be equipped with or adaptable to the use of slide and film projectors and ETV. Both can be used for staff or student conferences, or for formal but unscheduled classes or seminars. A data processing room for use both by faculty and graduate students is also an advantage. Special equipment need not be elaborate, and may include an adding machine, a calculator, and a typewriter.

A storage room easily accessible to staff offices and research facilities is a major convenience. Properly planned, it can always be converted into office space—a much-needed insurance against eventual overcrowding.

Every full-time faculty member and graduate student will need office and research laboratory space. These needs are discussed in chapters 17 and 18. In addition, an unassigned research laboratory should be considered for each department (fig. 5).



FIGURE 5. Departmental laboratory for research in histology.

LABORATORIES

The traditional arrangement for basic science teaching provides a laboratory of class size for every department. Since the faculty for each major discipline is usually organized as a separate department, this arrangement, in theory at least, calls for a separate laboratory for anatomy, biochemistry, physiology, microbiology, pathology, and pharmacology.

Considerably less space will be needed for undergraduate teaching if multidiscipline laboratories are used, and dental schools have generally found that more than one discipline can easily be scheduled for a single laboratory. Schools which use integrated systems of instruction or which need to assure a marked degree of flexibility will necessarily plan multidiscipline laboratories.

Other schools may find that the space economies made possible by a multidiscipline arrangement permit more generous programming of the special-purpose laboratories needed for research and advanced study.

If they are equipped with movable partitions and four- or eight-man position benches, both departmental and multidiscipline laboratories of class size are easily divided into smaller units to accommodate research projects or small group teaching. Many educators, however, look with increasing favor on the laboratory designed specifically for the smaller number of students. As yet, there is no consensus as to what the exact number should be.

Figure 6B is a photograph of a four-student laboratory used by freshmen for all of their laboratory work in both the basic and preclinical dental sciences. Figure 6A is a floor plan showing how items of equipment are placed. Sophomore laboratories have no anatomy table but are otherwise similar.

LAYOUT AND EQUIPMENT OF UNIT LABORATORY FOR BOTH BASIC AND PRECLINICAL SCIENCES

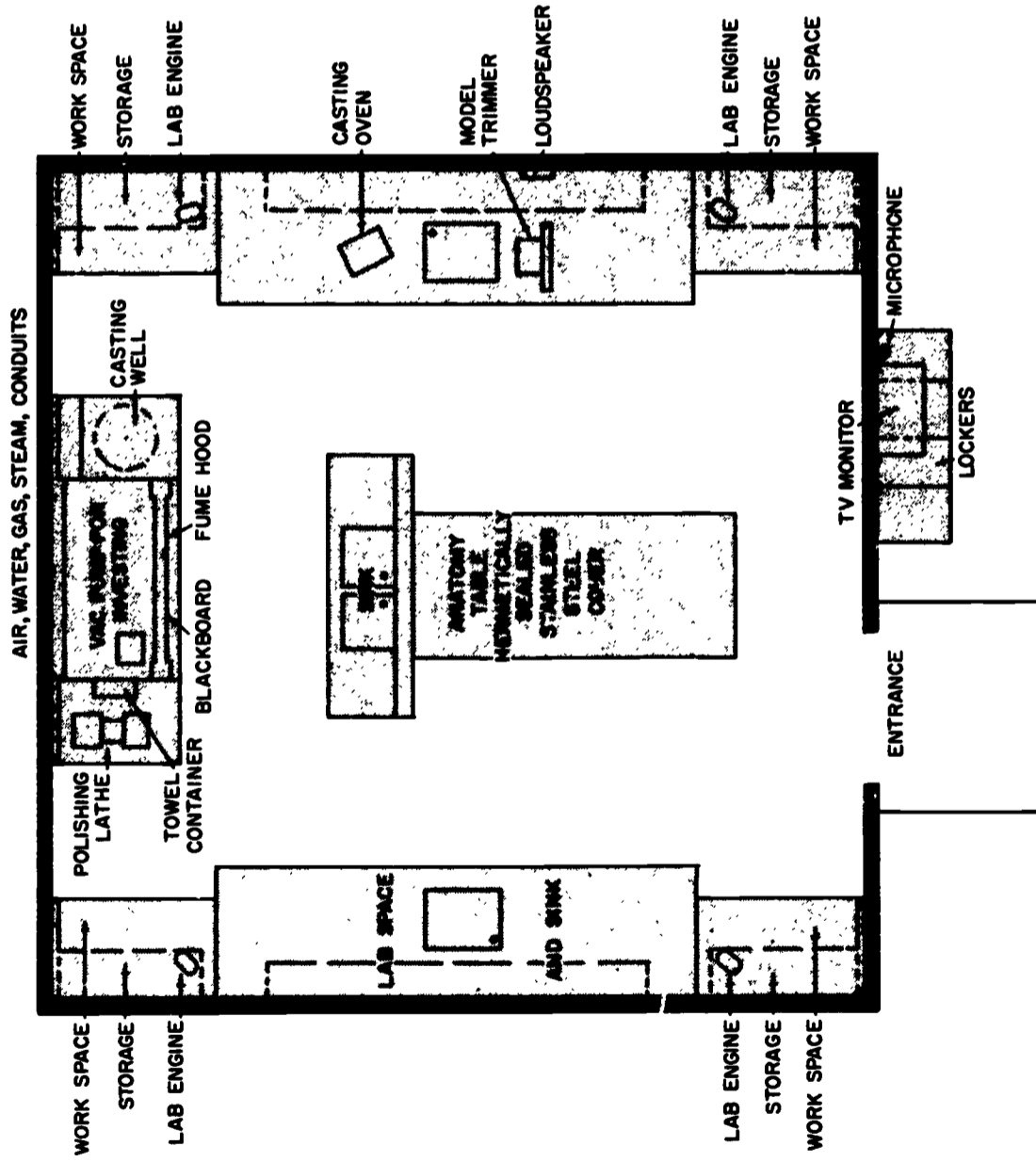

FIGURE 6A.

16-MAN TEACHING LABORATORY

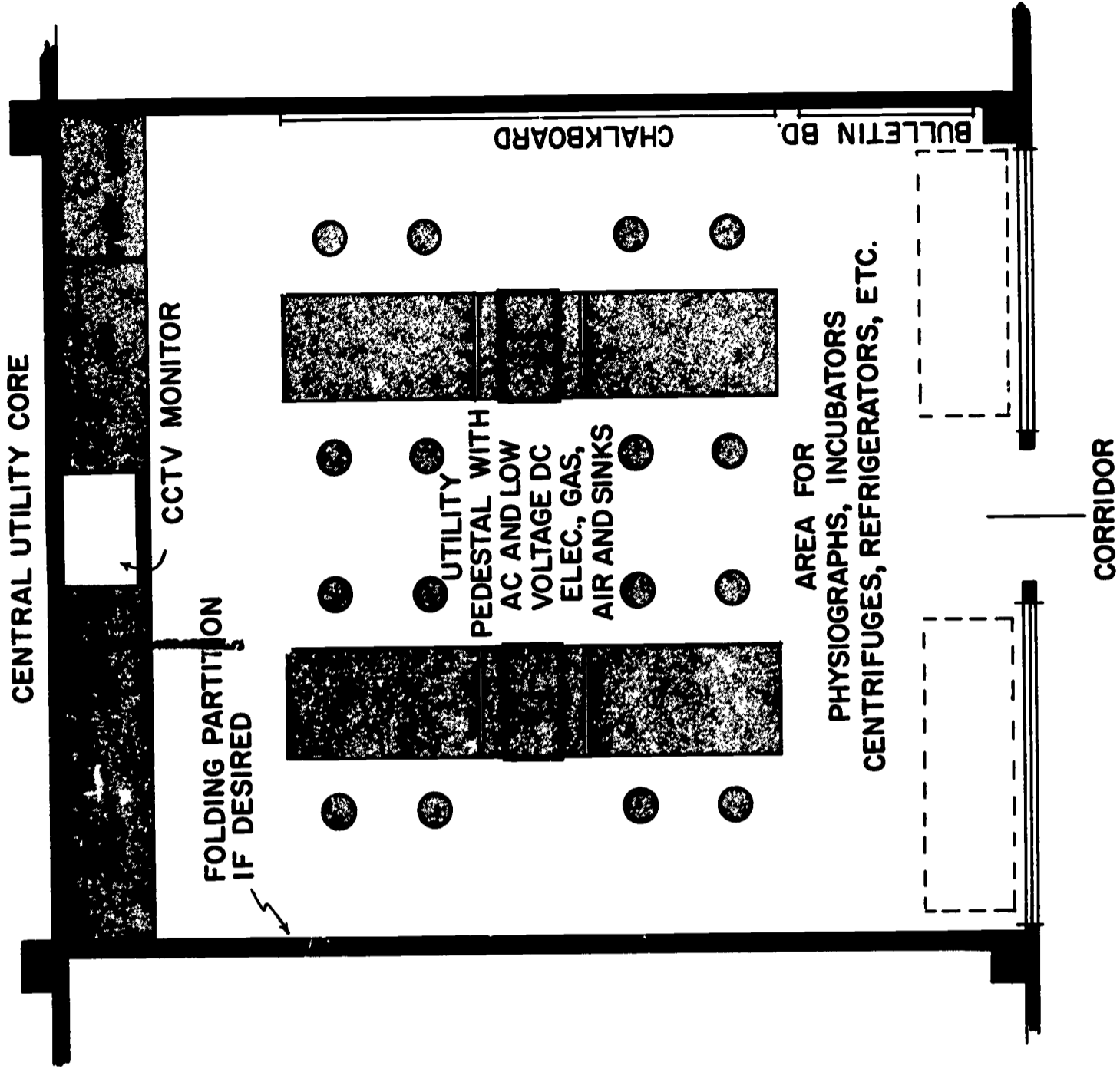

FIGURE 7.

Unit laboratories accommodating a larger number of students and designed for teaching only the basic science disciplines are more widely favored. Figure 7 is a floor plan of a 16-student laboratory in which physiology, biochemistry, and pharmacology are taught. More detailed information on the arrangement and equipment of teaching laboratories, and the special facilities associated with them will be found in chapter 10. Suggested space allowances are shown in appendix II.

FIGURE 6B. Freshman unit laboratory equipped with TV monitor.



10 BASIC SCIENCE LABORATORY FACILITIES

Three teaching laboratories—two multidiscipline and one single discipline—are described in this chapter. Together, the three can accommodate all of the basic laboratory sciences taught in a dental school.

Each of the multidiscipline laboratories described may be laid out as a series of self-contained units accommodating small groups of students, or retained as a class-size laboratory and equipped with folding partitions to permit division of the room into smaller units.

The ancillary and special facilities required by the different disciplines using these laboratories are generally described, and they are substantially the same whether small-group or class-size laboratories are utilized. For a more detailed discussion, and one of particular value to schools interested in departmental laboratories, planners should refer to *Medical School Facilities*.⁵

See references on p. 111.



LOW-BENCH DISCIPLINES

TEACHING LABORATORY

The disciplines which share the low-bench teaching laboratory are those employing microscopy as their principal technique—histology (the microscopic study of normal tissue), pathology (the microscopic study of diseased tissue), and microbiology (the study of microorganisms) (fig. 8).

Laboratory Benches and Arrangement.—Laboratory benches are usually 30–32 inches high to permit students to sit comfortably for long sessions at the microscope. Stools have back rests and adjustable seats. Either single or double-width benches may be used. However, because all students sit along one side of single-width benches, these can be more easily arranged to permit all students to face the demonstration area. A four-position bench is particularly desirable in the class-size laboratory, since it permits the division of the class into groups of 16 or less without splitting the group at any bench. If double benches are used, the eight-position bench is preferred.

Clearances of 3 feet between single-width benches and 4'6" between double-width benches are required. Side aisles, center aisle, and main cross aisle should be 6 feet wide.

Work Station at the Bench.—Each position at the bench should be at least 42 inches wide to allow both adequate knee space and room for a base cabinet containing drawers for storing slides and supplies and a cupboard for storing a microscope. Water, gas, and electricity should be available at each position. The need for an air outlet is limited, and a vacuum is seldom used. A lead cup sink at each position (or a bench-long drain trough with a sink at one end) is necessary.

Bench Tops.—Bench-top surfacing should be resilient, to minimize slide breakage, as well as stain and alcohol resistant. Bench tops should be as free of joints as possible.

FIGURE 8. Low bench laboratory, where the microscope is the principal tool.

Standup Work Areas.—Wall counters (37 inches high) are located along the sides of the laboratory area. These provide bench space of standup height, where students may set up portable equipment, conduct experiments with animals, or take part in other assigned projects. Counter top handwashing sinks with knee or foot-operated valves should be installed and supplied with hot and cold running water. Gas, air, and electricity outlets will also be needed. One set of outlets for every four work stations at the counter is adequate.

Demonstration.—The demonstration area should have a table, retractable projection screen, and a chalkboard at least 4 feet high and as long as the supporting wall permits. Additional small chalkboards—3'x4'—should be available throughout the laboratory. At least one for every 16 students should be provided, and all chalkboards should have adequate illumination. A bulletin board is also advisable. Because small-group laboratories easily accommodate demonstrations, no separate areas are needed for this purpose in schools employing the unit arrangement. Each of the small-group laboratories will require its own projection screens, chalkboards, and a bulletin board.

Stationary Equipment.—One noncorrosive fume hood should be provided for every 16 students. Stationary centrifuges in the same ratio are desirable for microbiology. Space will be needed for incubators—one for every eight students—and for refrigerators—one for every 16 students.

ANCILLARY FACILITIES

Each discipline sharing the low-bench teaching laboratory must have certain ancillary facilities available.

Space for the preparation of microscope slides is necessary for any laboratory in which histology and pathology are taught. Preferably, this area consists of two interconnecting rooms. In one, the embedding room, tissue is processed and embedded in paraffin. This room should have two counters, 31 inches in height, one to be used as a work-

bench for preparing and processing specimens and the other for mixing solutions. Placing a plain worktable at one end of the paraffin oven provides an efficient arrangement for the embedding procedures. For easy access from either side, the worktable should be located near the center of the room. Wall cabinets for storing solutions and other supplies should be provided.

The second room is used for sectioning, staining, and storing the completed slides. Counters 31 inches high and 2 feet wide should be provided in this room. Each work station at the counter should have knee space of sufficient width and a base unit with drawers for storing blank slides. All of the countertop in these slide preparation rooms should be resilient and stain-resistant.

For microbiology, a media preparation room should be provided adjacent to the teaching laboratory. Usually the work of a trained technician, media preparation requires space for several items of equipment, including a range or hot plates for cooking the material, an autoclave for sterilizing test tubes and media, a refrigerator for storage of culture media, and often an incubator for testing the sterility of media prior to use. This area should be dust-free. Wall counters 37 inches high, equipped with base cabinets and air, gas, distilled water and electrical outlets, are needed both in the kitchen area and in the area where media are transferred to test tubes. In the latter, burette stands are normally placed on the counter top.

A fairly large area for glassware washing and sterilization should adjoin the teaching laboratory. Commercial glass-washing and drying machines, an autoclave, and often a hot air sterilizer must be accommodated, as well as sink and drainboards, space for storing the carts which carry glassware and Petri dishes to and from the area, and a worktable for glassware storage.

Storage rooms for chemicals, glassware, equipment, and other materials are necessary. Among the items of portable equipment which may be used and will require space for storage are water baths, incubators, and spectrophotometers.

An animal holding room where small animals may be held for observation or experimentation completes the list of the larger ancillary areas required in conjunction with this laboratory.

SPECIAL FACILITIES

Additional facilities which are of special value for research and teaching in the low-bench disciplines include a coldroom and electron microscope setup.

The coldroom is essentially a refrigerator room. It contains counter space and sink for work that must be done at low temperatures. Safety door latches and warning lights are mandatory features.

An electron microscope unit requires at least three rooms—one to house the microscope itself—another for slide preparation, and a third—a darkroom—for developing, enlarging, and printing electron micrographs.

HIGH-BENCH DISCIPLINES

TEACHING LABORATORY

The disciplines which share the high-bench teaching laboratory are those for which laboratory work requires that the student stand and move about to perform experiments. These include physiology (the study of the process of living organisms), pharmacology (the science of drugs), and biochemistry (the study of the chemical compounds and processes occurring in organisms).

Laboratory Benches and Arrangement.—Laboratory benches are usually 37 inches high. Stools of adjustable height are provided. Except for their height, benches may be similar in design and arrangement to those in the low-bench laboratory. The four-position bench has particular merit because much of the work, especially in physiology, consists of special projects undertaken by a team of four students (fig. 9).

Work Station at the Bench.—The student's work station is also similar to that in the low-bench lab. Each station should have a base cabinet with both drawer and cupboard space. Adequate knee room should be provided, even though students stand a good share of the time.

Hot, cold, and distilled water should be available at each bench position. Gas and electricity are also required. In addition, low voltage direct current and control circuits should be available from a central panel.

Bench Tops.—Bench tops should be of stone or of acid-resistant composition stone because of the reagents used in biochemistry.

Sit-Down Work Area.—Low counters, with resilient counter tops, and under counter cabinets are placed along one or more of the laboratory walls. Gas, hot and cold water, air, and electric outlets will be needed, and countertop sinks



FIGURE 9. High bench laboratory equipped with folding partitions for greater flexibility of use.

should be equipped with knee- or foot-operated valves for hand-washing. Stools with adjustable seats should be provided.

Demonstration Area.—The demonstration space and equipment are like that of the low-bench lab. In addition, physiology teaching makes extensive use of electric polygraphs and the Van Slyke machines, often to the extent of one to each four students. If the unit laboratory is used, no demonstration area is necessary since each unit can easily accommodate demonstrations.

Stationary Equipment.—Fume hoods—one to every 16 students—should be provided. Because flammable and explosive chemicals are used, the hoods should be installed a safe distance from fire exits. Burette stands, approximately 5 feet in length, are used by both biochemistry and pharmacology students. One to every 16 students is an accepted ratio.

Movable Equipment.—A great variety of movable equipment may be used. A few movable tables of standup height may be required for some of the experiments in pharmacology and physiology involving animals. Table tops are of laminated wood with a stain resistant finish, and a shelf is provided for storing animal boards. In addition, a deep-freeze unit, centrifuges, refrigerators, incubators and much of the electronic apparatus used in physiology are part of the movable equipment used in the laboratory for which space is required. First aid kits and blankets are necessary, although these generally occupy no floor space, but are mounted on the wall.

ANCILLARY FACILITIES

Both biochemistry and pharmacology require a preparation room adjacent to the teaching laboratory for mixing reagents and storing chemicals and glassware. Storage and washing facilities are included in this room. Wall counters similar to those in the teaching laboratory and wall cabinets permit this room to be used as a research area during off periods.

Each discipline requires storage and supply areas, some of them special in nature. Special provisions must be made, for example, for storing anesthetics. Although only a limited supply of cylinders holding oxygen or anesthetics should be kept here (additional storage should be allotted at ground level), the storage area should be located along an exterior wall, with floor and ceiling louvers installed to provide gravity ventilation. The room should be locked. For chemical storage areas, fire hazards must be minimized. Narcotics require locked storage. Generally, rooms used to store instruments and equipment should be amply supplied with electrical outlets so that equipment can be used without being removed from the room.

Animal rooms and coldrooms are among the other facilities used regularly in conjunction with the teaching program of the high-bench laboratory.

SPECIAL FACILITIES

Many of the special facilities used for research and teaching in the high-bench disciplines require unusual construction or safety features.

The *chromatography* room is a biochemistry research laboratory where various processes are employed to separate organic substances. In laboratories where paper or column chromatography is performed, fume hoods capable of exhausting toxic or inflammable vapors are required, and the laboratory must be maintained under negative air pressure to prevent the spread of vapors. Where gas chromatography is used, it must also be possible to seal off the laboratory in the event of fire. Some instruments used in this laboratory depend upon radioactivity as an ionization source; if these are installed, safeguards must be provided, even though the radioactivity level is low.

In the *ultracentrifuge* room, another small laboratory often used in biochemistry research, the selection of equipment will largely determine the requirements. Depending upon its anticipated use, the ultracentrifuge may be either electrically powered or air driven. At least part of the hous-

ing for this equipment is of heavy armor plate. Additional cooling may be needed in the room to offset heat produced by operation of the equipment.

Constant-temperature rooms, or controlled-temperature rooms, as they are sometimes called, are used to quarter small animals under constant temperature and humidity conditions. The work area in this room usually consists of 31-inch-high counters, with a sink and outlet for gas, air, and electricity. Space may be needed for countertop food storage. At least one floor drain will be required so that the room may be completely washed down.

Because radioisotopes are widely used today in the diagnosis and treatment of disease, the *radioisotope laboratory* is a research facility of great value in a dental school. However, special precautions must be taken in locating, constructing, and equipping the laboratory.

The space allotted should be divided into two rooms, the radioisotope laboratory proper (radiochemistry laboratory) and the up-take-measuring room (counting room).

The radiochemistry laboratory is the room where shipments of radioisotopes are received and stored. Here, too, specimens are made ready for examination, and dosages are prepared and administered. Items contaminated with radioisotopes are either cleaned, held for decay of radioactivity, or stored prior to disposition.

In the counting room, the uptake of the radioactive substance is prepared and the radioactive content of specimens is accurately determined by use of radiation measuring devices such as Geiger counters or scintillation detectors. If the counting room is separated from the radiochemistry laboratory by a corridor, the possibility that stored isotopes will interfere with counting can be substantially reduced.

The location of the radioisotope laboratory some distance away from X-ray equipment prevents interference with measurements of radioactivity. The basement is usually the best location, since it simplifies provisions for waste disposal and shielding. In most schools, a basement laboratory will

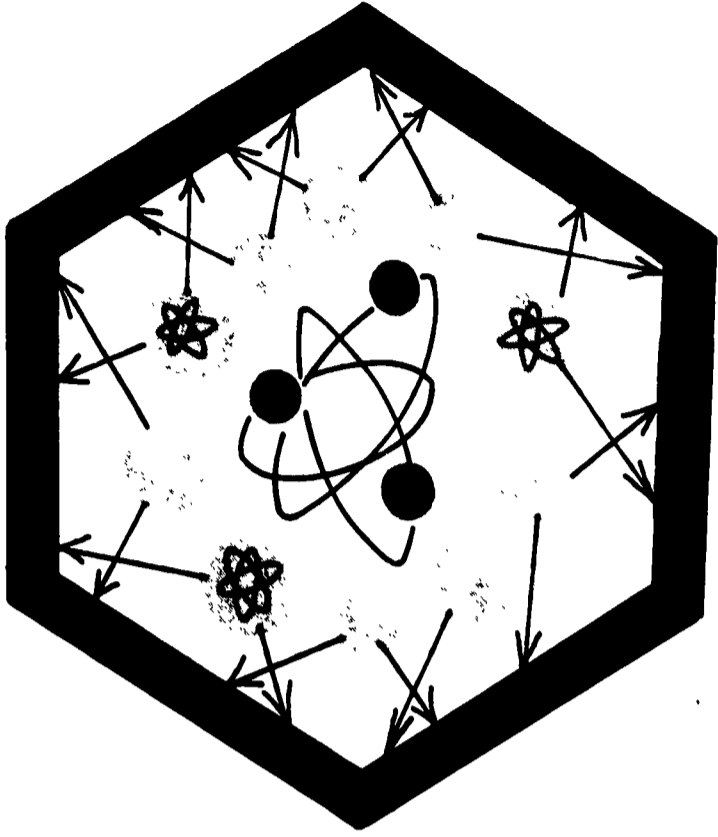

also be convenient to the central animal quarters, and this is highly desirable. If the main radioisotope laboratory is some distance away from these animal quarters, schools may want a separate and specially designed radioisotope laboratory within the animal quarters.

Safety features and special devices are essential, both to protect the students and staff from radiation exposure and to reduce the possibility of eventual contamination of the facilities.

Wall shielding is a necessary safeguard against radioactive penetration, and the average building partition will not usually suffice for this purpose. Plastic, wood, or other light material is adequate shielding against beta radiation. Solid concrete or solid brick walls will be necessary for protection against gamma rays. The laboratory worker inside the room, when unsealed radioisotopes are used, will wear special garb to protect himself against radioactivity.

ANATOMY

Interior wall surfaces should always be of a smooth, non-porous material. High gloss enamel paint is best suited for this purpose. To facilitate decontamination, stripable vinyl plastic or replaceable wall panels are installed near sinks and other critical areas.

The floor in a radioisotope laboratory is usually a concrete slab. The slab must have a protective covering or coating to prevent radioactive contamination from spillage. Heavy waterproof paper can be used, but newer materials, such as epoxy-resin surface coating compounds, can be troweled on to the concrete slab and offer greater protection. Polyethylene film (.004 inch), carefully laid in cold mastic or adhesive, is also effective. Asphalt and other types of tile provide a wearing surface which can be replaced if it becomes contaminated. The floor should always have a heavy wax coating, which will fill cracks and serve as waterproofing.

Countertops should be stainless steel, with splash-back trims. They should always be covered with disposable diaper paper. Cafeteria-size stainless steel or enamel trays, lined with paper, also reduce the contamination hazard.

Sinks should be made of stainless steel and equipped with foot or knee controls. Each sink should have two drainboards, one for clean and the other for dirty glassware.

Holding tanks must be provided for the collection of large amounts of radioactive materials or small amounts of the more dangerous isotopes.

Special radio-chemical fume hoods are necessary. Because of the dangers of air movement, hoods should never be placed near windows, doors, or ventilators.

The exhaust system, with its special requirements, should be carefully considered.

A deluge shower will also be needed.

Storage of moderate amounts of isotopes can be cheaply and satisfactorily managed by keeping the shielded batches in shipping pots and placing them on a dolly parked under the fume hood.

In the teaching laboratory of the anatomy department, dental students study the structure of the human body. The principal technique employed is dissection. The teaching laboratory, called the gross dissection room, and its ancillary facilities can be used for any anatomy course in which gross specimens are dissected, including neuroanatomy and embryology (fig. 10).

THE DISSECTION ROOM

Dissection tables are the basic laboratory equipment. They are approximately 24" x 78". Aisles at the table sides should be 5 feet wide and those at the ends 3'6".

Dissection rooms are, as a rule, planned to accommodate full classes. Though class size largely determines room size, space should be allowed to accommodate a few additional tables for use by graduate students and for demonstrations.

Good table lighting is essential. Often, adjustable lighting fixtures are attached to both sides of each table. If tables are on casters, cleaning of the room will be considerably easier.

The dissection room should be equipped with an adequate number of hand basins. Round, industrial sinks are a good choice, since they accommodate more students simultaneously than those of standard design. One sink for every four tables is an accepted ratio.

The dissection room should include counter units with drawers and cupboards for storing students' instruments. Storage space should also be provided for such supplies as wood blocks, mallets, armrests, embalming fluids.

Because of the odor of the preserving fluids, air conditioning with a 100 percent air exhaust should be provided in the dissection room, whether or not it is installed in the rest of the school.

As the anatomy dissection room is frequently washed down, durable, waterproof flooring is required. Quarry tile and terrazzo are excellent. Newer schools have also used asphalt tile successfully.

LAYOUT OF ANATOMY LABORATORY OF CLASS SIZE

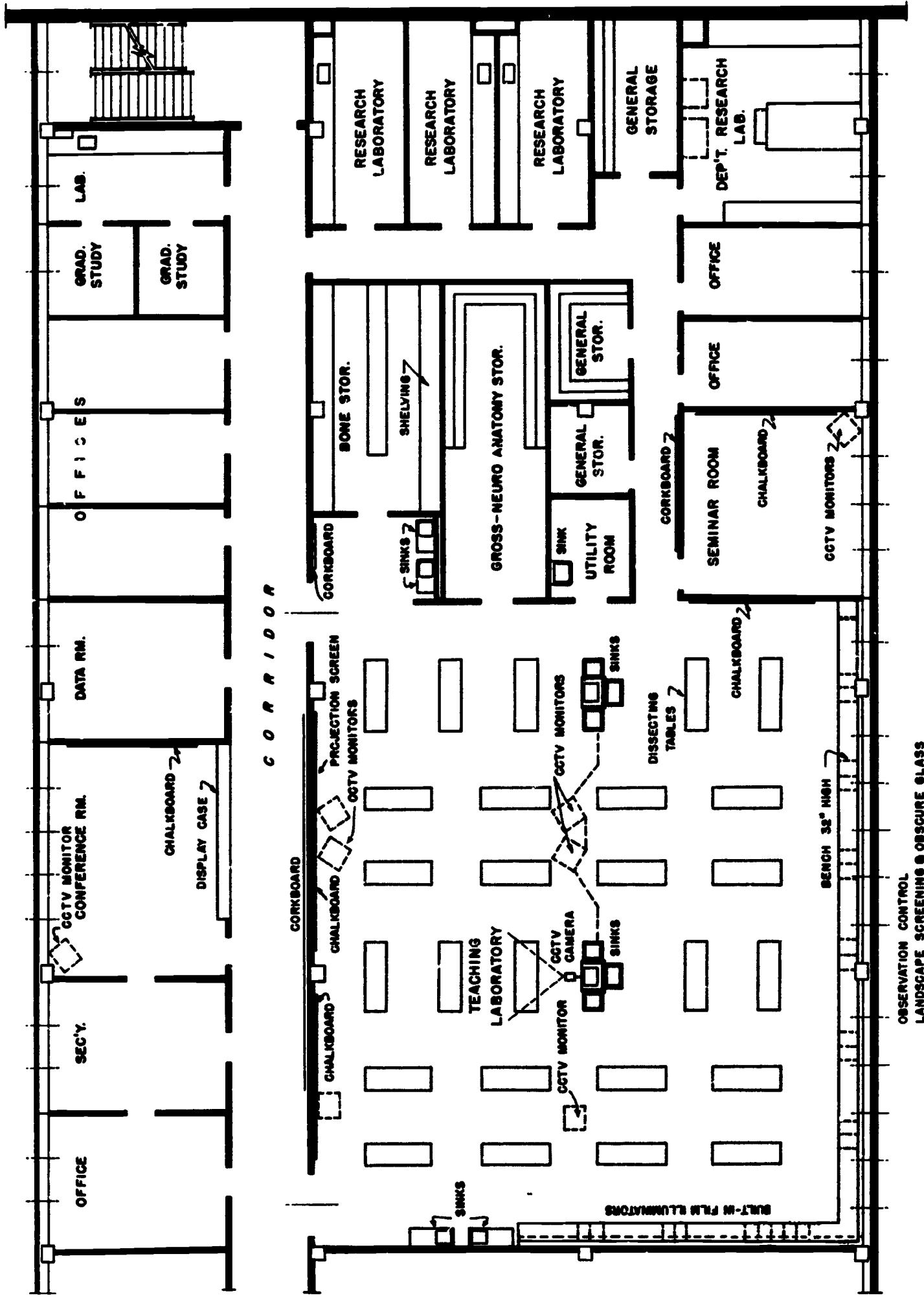

FIGURE 10.



Because dental students usually study gross anatomy for only one semester, the dissection room is often unused during half of the school year. Providing storage space for the dissection tables will make it possible to use the dissection room for other purposes during off-semester.

ANCILLARY FACILITIES

Several additional rooms either near or adjacent to the dissection room are required. Storage space for cadavers must be provided and bone storage space will also be needed. If neuroanatomy is taught in the dissection room, storage for gross specimens must be available, too.

Generally, schools will need sufficient storage capacity for 1.5 cadavers for every four ECS. If the school policy is to hold cadavers for one year prior to use, storage requirements will double. Cadavers are commonly stored in large walk-in refrigerators. However, a properly embalmed body can be

kept for 5 years without refrigeration. Because the method of preservation and storage affects ancillary space requirements, the system to be used should be determined early in the programming stage, and specifics should be worked out with the aid of qualified consultants.

A room equipped for embalming is often provided, though dental schools with access to medical school facilities will probably need only a minimum of space for this purpose. As for final disposal, cadavers are usually cremated. The dental school can either provide its own crematory for this purpose, share facilities with a medical school, or arrange periodic transfer of cadavers to public facilities for cremation.

Because it should never be necessary to move cadavers through public areas, facilities for cadaver storage and embalming should be as near as possible to the dissection room, and all three should be located at ground level. Wherever practical, loading platforms should open directly into the cadaver storage area to facilitate delivery and removal.

CLINICAL FACILITIES

AND PRECLINICAL FACILITIES

11. PRECLINICAL FACILITIES

12. CLINICS: FUNCTION AND OPERATION

13. CLINICS: SPACE ALLOCATIONS AND RELATIONSHIPS

Part

11 PRECLINICAL FACILITIES

In his freshman and sophomore years, the dental student receives intensive training in the fundamentals of operative dentistry and of pedodontics, endodontics, orthodontics, and oral surgery, mastering the techniques he will later employ for the benefit of patients in the school's clinics. Most instruction is given in the laboratory itself, with instructors from the different clinic departments teaching small groups of students the theory and techniques of each type of treatment. Formal lectures are usually held in one of the school's lecture rooms.

THE PRECLINICAL LABORATORY

The preclinical laboratory is designed to accommodate the entire class of freshman or sophomore students in a single session. Some schools have only one laboratory, which is used alternately by the two classes, and they consider this arrangement satisfactory. But two laboratories, one for each class, undoubtedly permit greater flexibility in scheduling; as a result, conflicts in class schedules, particularly likely to occur in schools which lack their own basic science departments, can be totally eliminated. Schools which can afford the two laboratories will also be able to institute a system most educators consider highly desirable—that of assigning each student a permanent bench position, complete with individually locked instrument cabinet and drawers (fig. 11).

Though it is not often so-called, the preclinical laboratory is actually a multidiscipline laboratory, for all the preclinical dental science courses are taught here: the instructors of the

FIGURE 11. Preclinical laboratory benches with individual storage drawers and lamps.

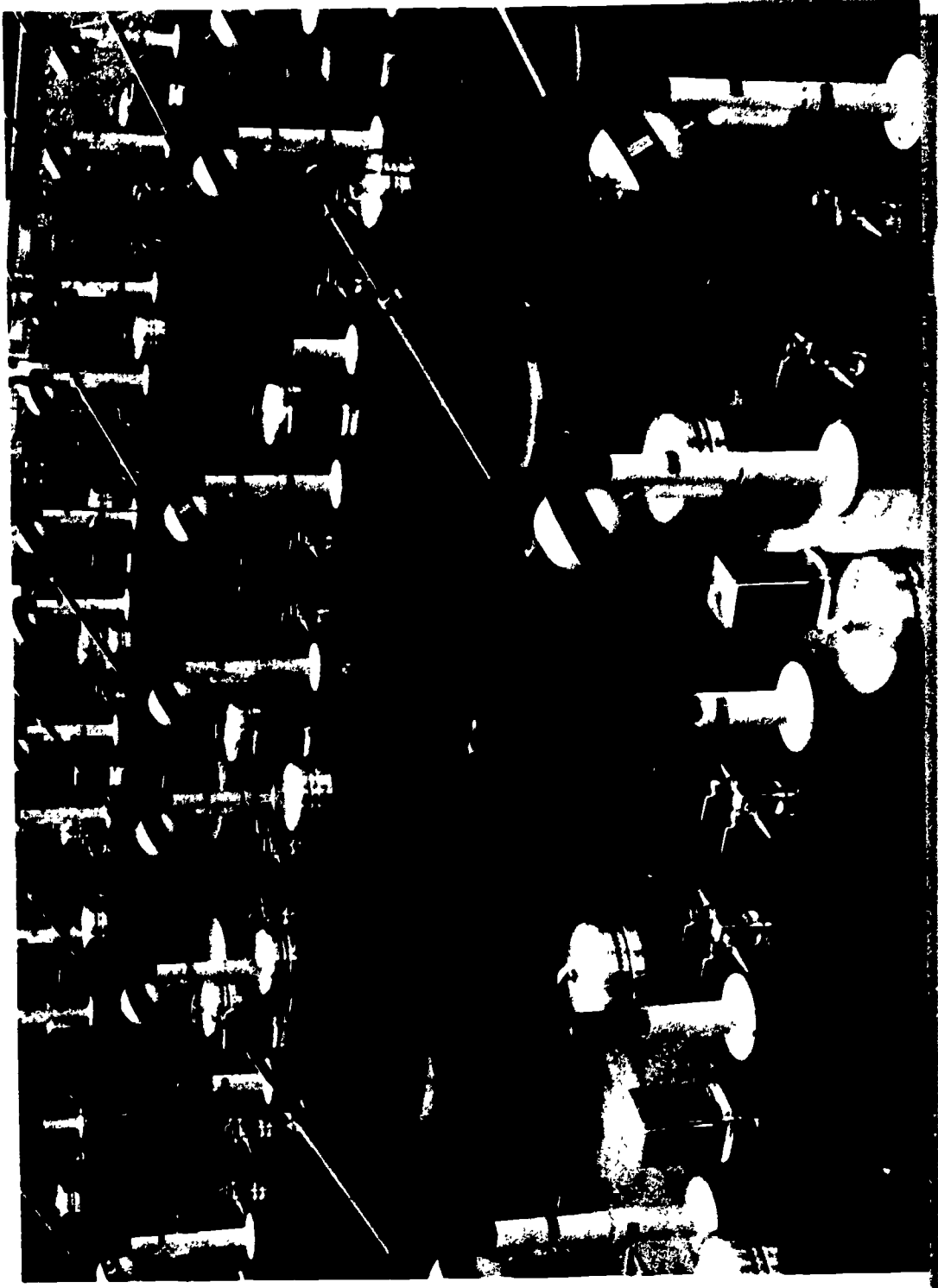
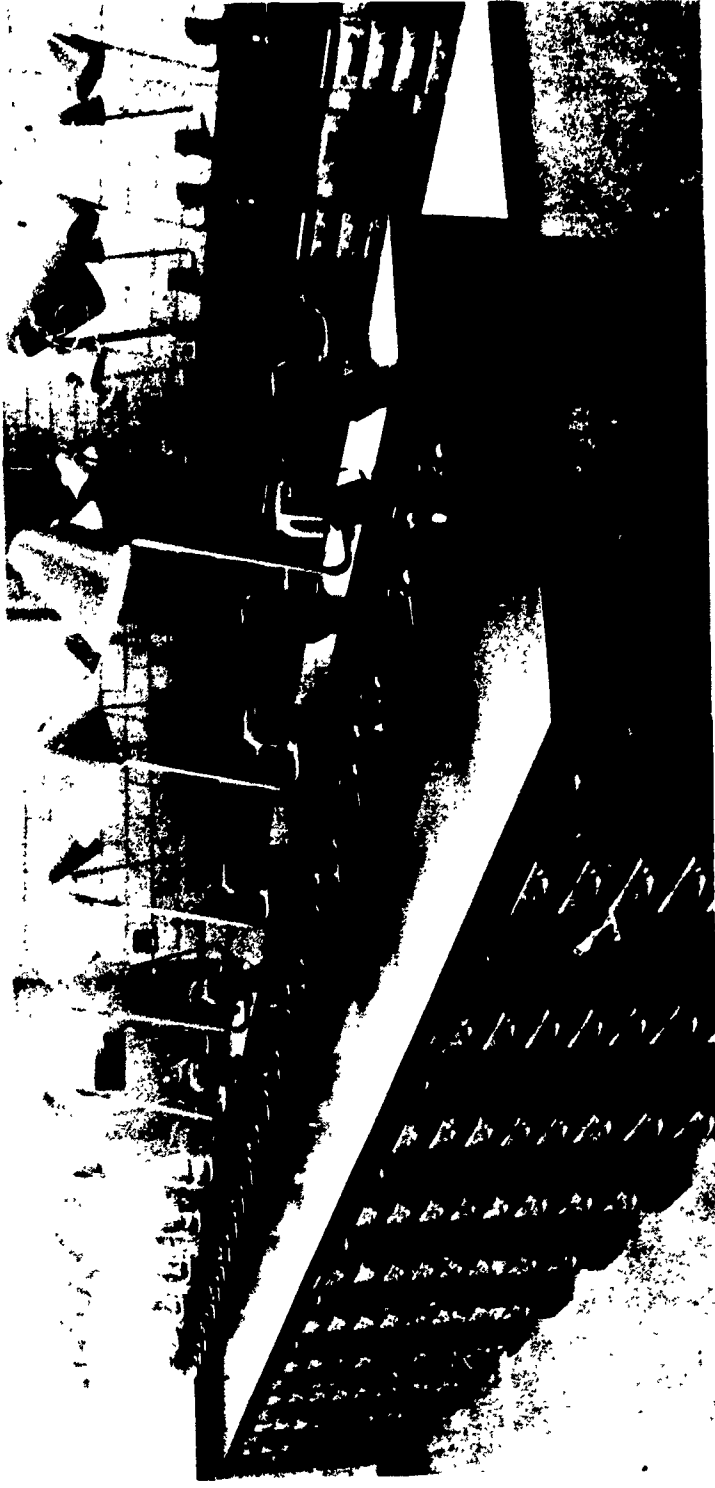

FIGURE 12. Conventional arrangement of preclinical laboratory benches, with dental motors and utility outlets at each position.

**PRECLINICAL LABORATORY OF 96 STUDENT POSITIONS
UTILIZING CLOSED CIRCUIT TV FOR DEMONSTRATIONS**

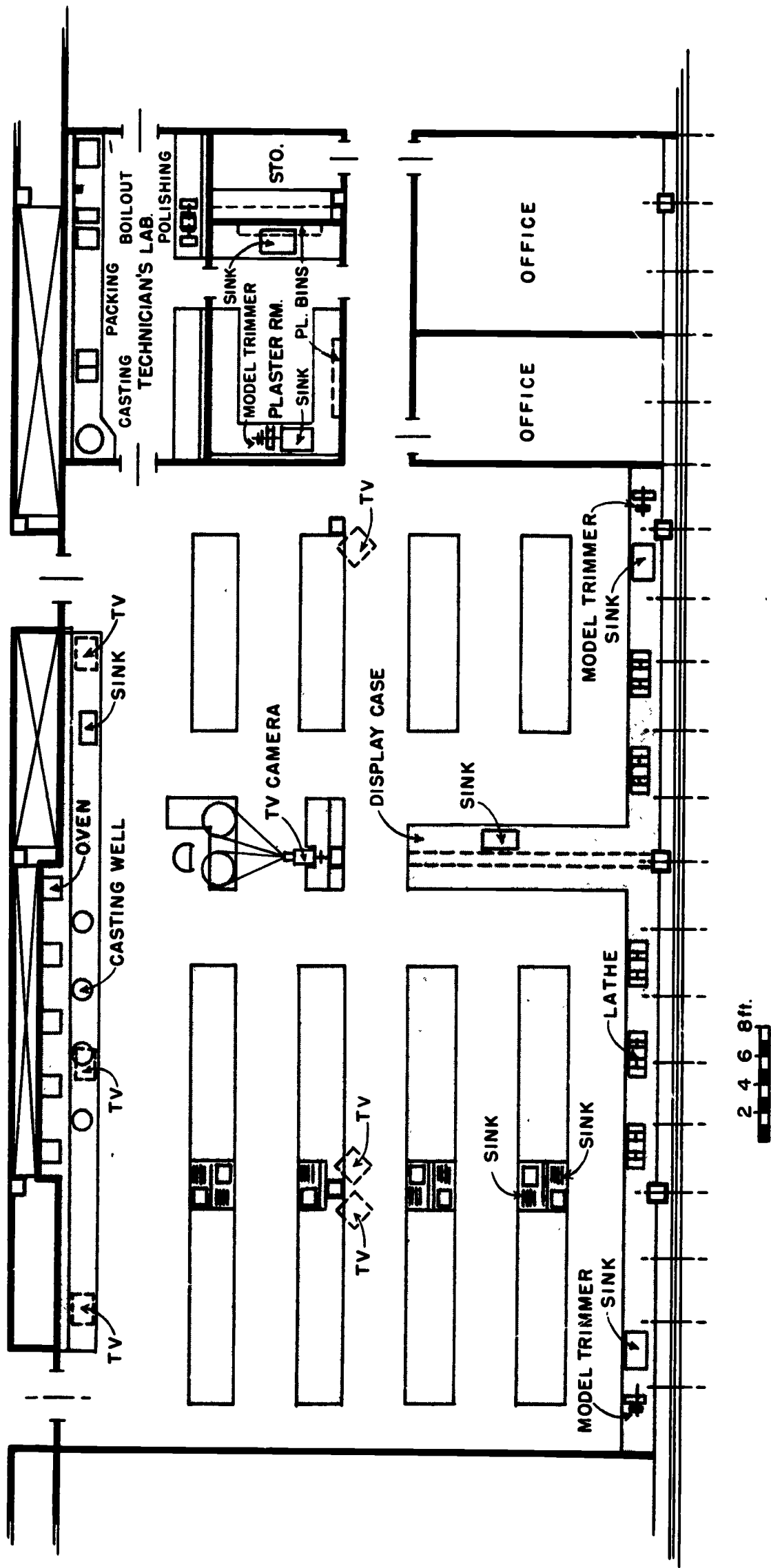

FIGURE 13.

several subjects take over the laboratory in turn while the students remain in their assigned places.

Seating.—In the arrangement most common to preclinical laboratories, students sit on each side of a bench, their backs to those of students at the next row of benches. The aisles separating the rows are at least 4'6" wide, so that the instructor may move easily between the benches as he inspects the students' work.

In some of the newer laboratories, benches are arranged so that all students face in one direction—usually toward the instructor's podium. This gives students a better view of the chalkboard or a projection screen. The aisles between benches—a 3 foot minimum is satisfactory—are not as wide as those required for back-to-back seating. On the other hand, back-to-back seating is economical. It conserves floor space and reduces the cost of bench work and utilities.

In either of the two seating plans, high or low benches can be used, but the low bench—32 inches in height—will perhaps be the more satisfactory. With low benches, a standard adjustable typing chair on casters can be used and is less costly than the laboratory stool. All benches should be equipped with gas, air and duplex electrical receptacles (fig. 12). Each student station at the bench should be at least 3 feet wide, and 3'6" is actually more satisfactory. If the latter figure is used, an over-all allowance of 38 square feet per student position will provide adequately for the teaching facilities.

Every preclinical technic laboratory should provide the instructor with a table or desk, equipped with gas, air, and electricity for demonstration purposes. In large classes which require more than one instructor, each should be allotted desk space.

Ancillary Facilities.—To reduce the tracking of plaster from the laboratory into the public corridors, the processing room, which is used for pouring wax forms, molds, impressions and flasks for denture processing, can be located adjacent to the preclinical technic laboratory. Also nearby should be a small storeroom.

ETV IN THE PRECLINICAL LABORATORY

Figure 13 shows a preclinical dental technic laboratory of 96 student positions together with an adjoining processing room. Demonstrations within the laboratory are given with closed-circuit television. There are 16 students per monitor. The monitors are also coupled to the television studio of the school.

This layout is also adaptable to the monitoring of students' work by closed-circuit television. In such a system, the picture is relayed to the console at the demonstration position.

While the principal medium of demonstration is ETV, facilities for chalk talks and for projection of motion pictures or slides are provided. Display cases, some of which permit viewing from both sides, should be provided for models and examples of student work. The laboratory shown has the equipment used in common by students, such as lathes, model trimmers, sinks, ovens and casting machines, located at the perimeter walls.

12 THE CLINICS: FUNCTION AND OPERATION

In the clinics, dental students gain experience in the correction and control of dental diseases and disorders (fig. 14). Here, too, the community finds an additional source of dental services, some of which are frequently unobtainable outside the dental school.

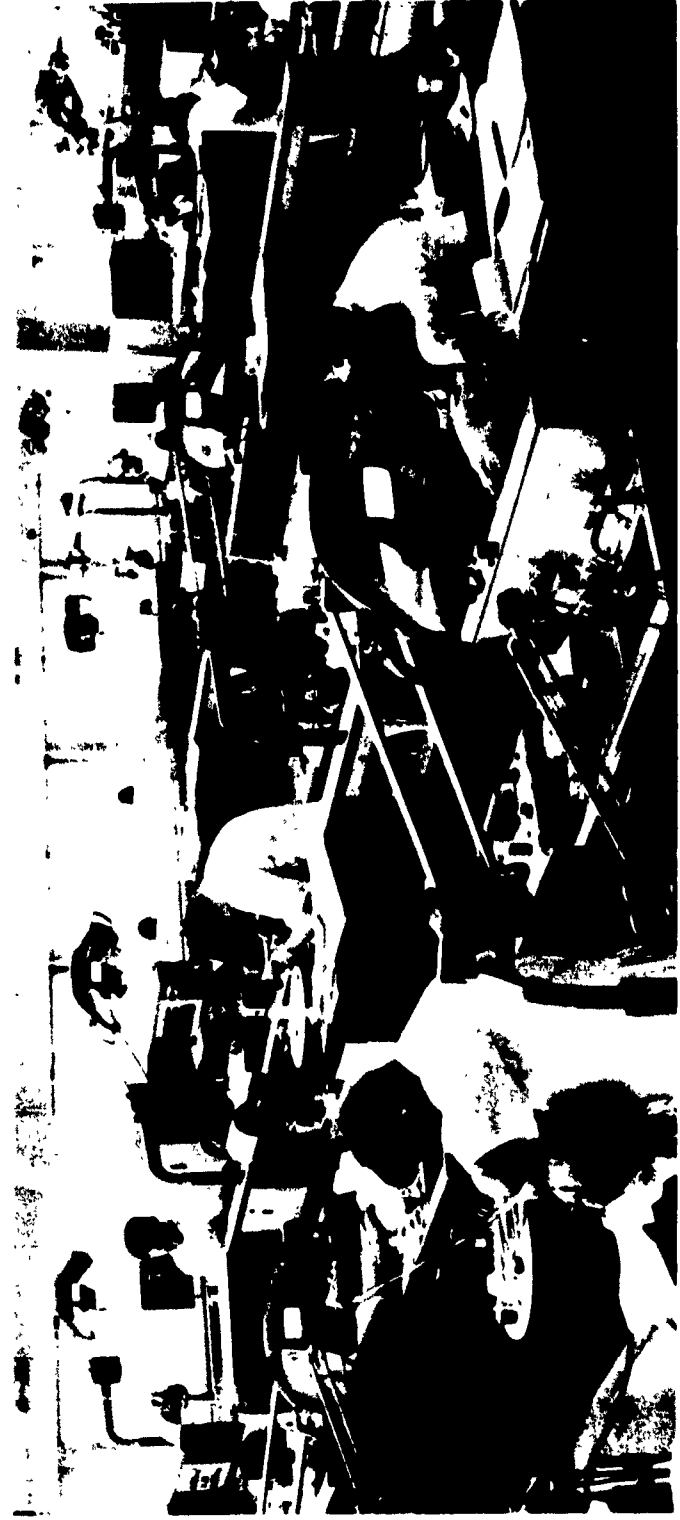

FIGURE 14. General clinic typical of many dental schools.

HOW THE CLINICS OPERATE

Even when all treatment is provided in a single large general clinic, specialized procedures such as oral surgery are given in areas designated and equipped for those particular purposes. Each of these areas is, in effect, an autonomous clinic. Today, however, the trend is toward the establishment of separate clinics, located in different rooms or on different floors from the general clinic, for specialized treatment procedures.

Whatever the variations in layout, the operation of the clinics is reasonably standard in every school. Perhaps the best understanding of the clinics, their components and functions, can be obtained from a review of patient movement through the three major clinic areas: reception and screening; examination, diagnosis and treatment planning; and treatment.

PATIENT MOVEMENT IN THE CLINICS

Figure 15 illustrates patient movement through the clinics. The new patient first reports to the information desk located in the lobby or main waiting room of the clinic area. He then proceeds to the registration desk, where a case record is opened for him. At the appointment desk, his next stop, he is scheduled for an oral examination.

The patient then undergoes, either on the initial visit or a subsequent one, a screening examination. This procedure enables the school to select patients with varied dental problems.

Following the screening examination, the patient goes to the radiology clinic for full-mouth roentgenograms and then to the diagnostic clinic for a thorough oral examination, performed by a dental student working under the direction of an instructor. When the examination is completed, the patient returns to the appointment desk where he is referred for subsequent visits either to the general dental clinic or to one of the special clinics. On later visits, the patient reports directly to the waiting room of the clinic where he will receive treatment.

FIGURE 15.

DENTAL CLINIC FLOW DIAGRAM

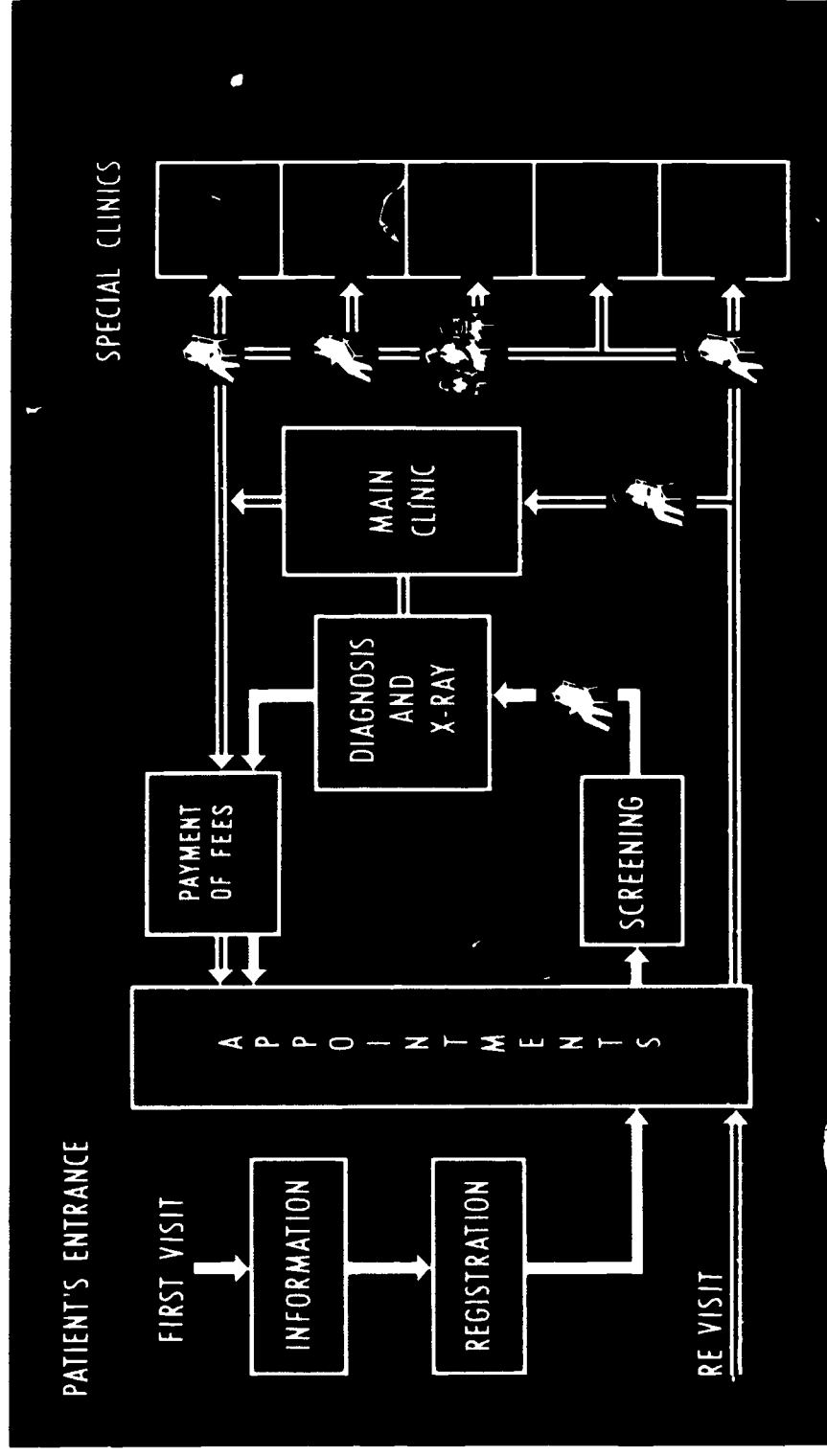

RECEPTION AND SCREENING AREA

The reception area in the main waiting room is the control center of the clinics, coordinating the flow of patients and records to clinics in the treatment area. In addition, the work of the appointment desk is closely coordinated with that of the clinic business office.

The components of the reception and screening area differ from school to school. Frequently the information, registration, and appointment desks are combined, but they may be separate in large schools, or information and registration may be handled at one desk while appointments are made at a second. Similarly, one or more of these desks may be located either in the main waiting room or in adjacent rooms.

The reception area will require a records office. All patient records in active use are issued and filed here, and the convenience with which records can be dispatched to the clinics is an important consideration in the location of the area. However, storage space for inactive records need not be provided here, as these are frequently microfilmed or moved after two years to storage rooms in other areas of the school.

Screening.—For the screening of new patients, an examination room separate from the diagnostic clinic is desirable. This room should be equipped with dental chairs. Dental units are not necessary unless the room will also be used for emergency treatment.

Emergency treatment rooms function as a part of the reception and screening area. Either a series of single-chair rooms or a large room with two or three dental chairs is practical. Although emergency treatment rooms are sometimes included in each of the clinics in the treatment area, the provision of central facilities is more likely to assure that the rooms are not preempted for some other purpose, such as the treatment of regularly scheduled patients during particularly busy periods.

EXAMINATION, DIAGNOSIS, AND TREATMENT PLANNING AREA

It is in the diagnostic and radiology clinics that the incoming patient's need for dental care is determined and a plan of treatment formulated.

The diagnostic and radiology clinics differ in equipment and components from each other and from the clinics in the treatment area. Graduate student facilities are less often provided in these clinics than in the general clinic or in other special clinics. Since both the radiology and the diagnostic clinics utilize central supply and dispensing facilities, neither requires additional space for this purpose.

Today demonstration operatories are a standard feature in the radiology clinic and in all treatment clinics; they are less common in the diagnostic clinic. In future, schools planning to use ETV for demonstrations may find their need for demonstration operatories considerably reduced.

THE DIAGNOSTIC CLINIC

Essential facilities in the diagnostic clinic include operatories or examination rooms, a clinical diagnostic laboratory, and a treatment planning and consultation room. Faculty offices and faculty research areas should be provided nearby.

Although multiple-chair rooms are sometimes used for examinations, a series of single-chair rooms assures privacy for the recording of patients' case histories. Each position should be equipped with an X-ray viewer. Estimating that 16 patients can be accommodated daily in each chair, an eight-chair facility could handle over 120 patients each day. In addition to dental chairs, the examination rooms should be furnished with desks for the convenience of students recording case histories.

The clinical diagnostic laboratory is used for hematological and other diagnostic procedures. It is equipped with laboratory benches similar to those used for the low bench basic science disciplines, but since students are assigned here in blocs, eight positions are usually sufficient. Air, gas, and

electricity should be available at each position, and both hot and cold water are desirable. A hand washing sink should also be provided. One standup laboratory bench should be located at the outer wall. Because patients seen in this laboratory are referred directly from the diagnostic clinic, no waiting room is needed.

The treatment planning and consultation room, where students and instructors meet to discuss cases, should be equipped with a chalk board, demonstration table, projection screen, and X-ray viewer, in addition to a dental chair and unit. The room can also be used for small group demonstrations.

RADIOLOGY CLINIC

Because roentgenograms are made for every incoming patient, the radiology clinic is included in the examination and diagnostic area. However, the radiology clinic also serves all the other clinics, and patients undergoing treatment are directed here for additional roentgenograms. Dental students are assigned to the clinic in blocs to learn to take, process, and interpret roentgenograms. Dental assistants and dental hygienists also receive instruction here.

Shielding Against Radiation

Because of the dangers of excessive exposure to radiation, few clinics present more exacting standards of construction. Rooms containing X-ray machines must be shielded through the use of lead-lined walls and partitions or appropriate building materials of an adequate thickness. In addition, controls for X-ray machines should be located behind shielded partitions.

In general, shielding should be sufficient to limit the exposure of personnel to a minimum amount of radiation, certainly no more than 0.1 roentgen per week. In rooms equipped with 90 kvp X-ray machines, for example, the walls should be shielded with 1.2 mm sheet lead (3 pounds per square foot) to a height of 7 feet. Stone concrete at least 3 inches thick should be used for ceiling and floor.

Further information on shielding can be obtained from the National Bureau of Standards, which strongly recommends that all new facilities equipped with X-ray machines be subjected to a protection survey directed by a qualified expert.

The Layout of The Clinic

Figure 16 shows the components and equipment of the radiology clinic. This plan includes eight rooms where the roentgenograms utilized in routine oral examinations are taken, and one extraoral radiology room, where the facial-profile and other extraoral roentgenograms required for orthodontic, prosthetic, and oral surgical procedures are exposed.

In the radiology rooms, the machine is located behind the dental chair, and up to 20 degrees to either side, the recommended position. Observation of the patient is made through a lead glass viewing window which has a speaking slot. Each of the rooms is equipped with a small chalkboard, illuminator, lavatory, and shelf. Room A, slightly larger than the others, has a 4-foot-wide opening to facilitate handling of wheel-chair and stretcher patients.

The extraoral radiology room is of slightly greater depth than the intraoral, because a long-focus film distance is required for the facial-profile roentgenogram.

Each of these rooms is lead-shielded, and the X-ray machine controls located behind lead-protected partitions.

Film Processing.—A suite of rooms for film processing includes a darkroom, oversized to permit group instruction, a wet viewing and drying room, and a mounting room. A framed opening in the wall between the drying and mounting rooms is used for passage of film. The mounting room accommodates eight students. Each student position has a 14"x17" view box built into the surface of the bench.

Air conditioning in the darkroom and wet viewing room is desirable not only for the comfort of personnel but for the protection of exposed film. Maintaining air at positive

RADIOLOGY CLINIC

ORAL DIAGNOSIS

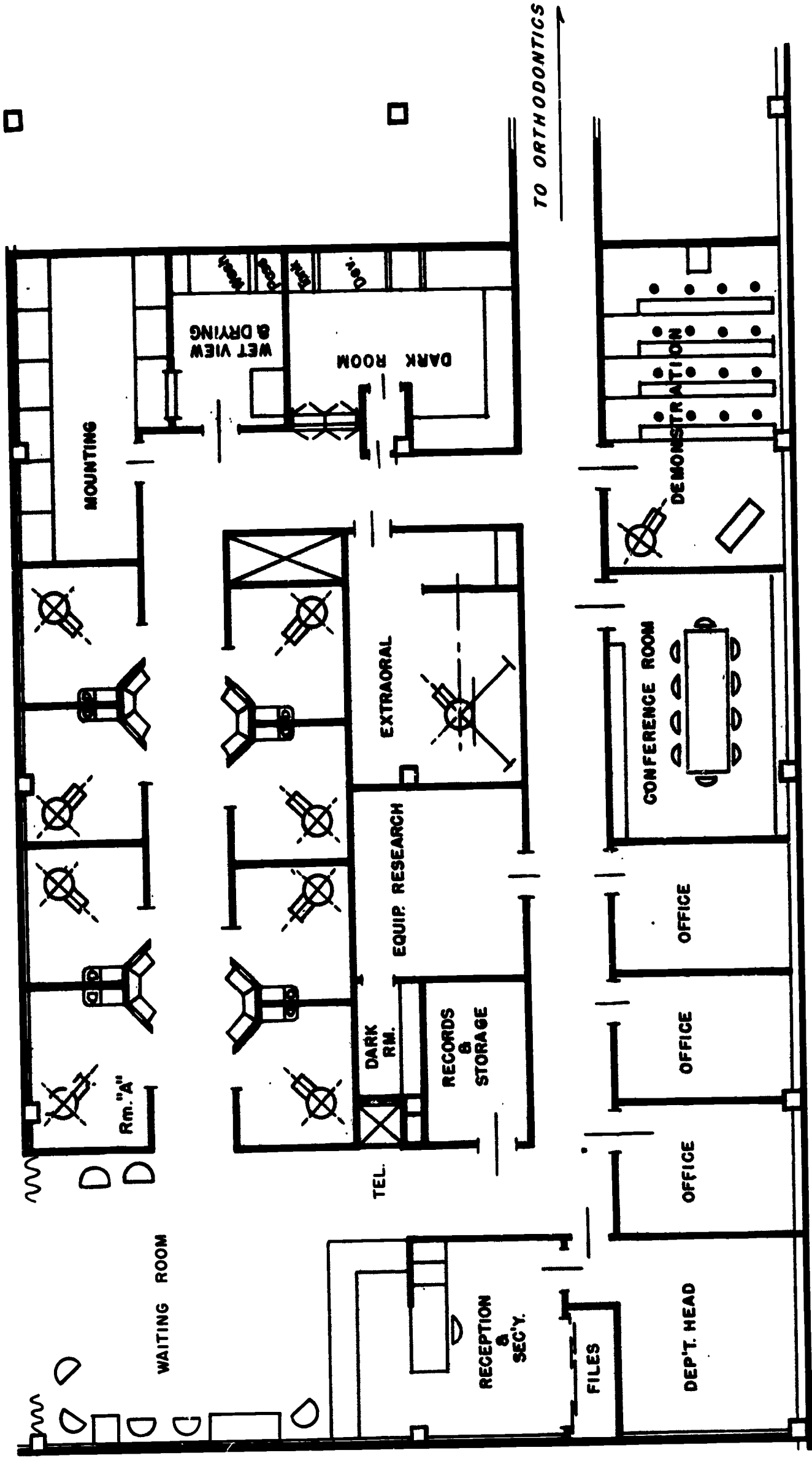

2 4 6 8ft.

FIGURE 16.

pressure will prevent dust from entering around windows and doors.

Ancillary Facilities.—The special demonstration room, which accommodates 16 students, has provisions for movie and slide projection and closed-circuit TV monitors. An exodontist's chair, a mobile X-ray unit, and a mobile lead screen are available for demonstrations. If ETV is used extensively for demonstrations, this room could be converted to a film library.

The departmental research area includes a small dark-room. A conference room, suitable for seminars and equipped with chalkboard, projection equipment, and an illuminated viewer, and a group of faculty offices complete the radiology clinic.

TREATMENT AREA

After examination and diagnosis, patients are referred to the treatment area. The great majority are treated in the general or operative dentistry clinic, where restorative dental treatment is given. Only those patients who require other types of treatment are referred to the appropriate special clinic.

THE GENERAL CLINIC

Because the general clinic is typically the largest and busiest of all the clinics, the main waiting room and control desks and many of the other elements already described are considered a part of it.

Treatment components include operatories, treatment planning and consultation rooms, supply and dispensing services, and sterilization and sterile supply facilities. Study and laboratory areas for the use of graduate students should adjoin.

The operatories, or work stations (fig. 17), into which all the clinics are divided, consist of dental chairs and units, instrument cabinets, sterilization units, and other necessary equipment. Each station should be large enough to accommodate the patient, the student who is treating him, the



FIGURE 17. In cubicle clinics, partitions separate each work station.

supervising instructor, and frequently a dental assistant. Several fully partitioned work stations should be provided to accommodate patients whose emotional reaction to dental care makes privacy mandatory.

THE SPECIAL CLINICS

The special clinics—periodontic-endodontic, orthodontic, and others—are differentiated primarily by the type of treatment rendered. One, however, is distinguished by the type of patient treated—the chronically ill, the mentally disturbed, and others who are unable to receive treatment under regular clinical conditions.

The same departmental facilities and most of the treatment facilities required in the general clinic are needed for each of the special clinics. Every special clinic should have at least one fully partitioned work station. Generally, each will have a small waiting room with control desks separate from

the main waiting room. However, related specialties such as pedodontics and orthodontics often share a waiting room.

Specific Requirements

Except for some variations in the design of the instrument cabinet, the basic equipment of the special clinics is the same as that of the general clinic. Most of the special clinics are equipped with standard dental chairs and units. The pedodontic clinic, however, requires a smaller chair and the oral surgery clinic special chairs or operating tables. And a few of the special clinics require additional components and highly specialized equipment. Clinics where general anesthesics are administered must have recovery rooms and toilets. A ceramics laboratory is sometimes maintained in the crown and bridge clinic.

The orthodontic clinic, where malocclusion and other dento-facial abnormalities are treated, requires a number of special facilities. Among these are a measure room where extraoral roentgenograms can be viewed and anthropologic measurements determined. A record room where current charts and models can be stored and a tracing room with a light table for routine tracing of roentgenograms are desirable, as is an office for technical personnel.

Clinics for special patients provide facilities for the treatment of spastic children, victims of cleft palate, and others with physical or mental handicaps. Patients requiring prosthetic devices to replace tissue loss resulting from oral cancer and other causes are also treated here. This clinic usually contains two or more rooms with specialized equipment. At least one dental chair which can be used when general anesthesics are administered is required.

Frequently facilities for periodontic and endodontic treatment and for oral medicines are combined in one clinic. If X-ray machines are provided, the clinic must be shielded in the same manner as the radiology clinic or a lead-lined partition provided around the X-ray machines.

Oral Surgery Clinic: A Special Case

Perhaps the greatest variation in the components and equipment is found in the oral surgery clinic.

Figure 18 illustrates an oral surgery department planned to accommodate blocs of eight students. Eight of its nine operatories are equipped for surgery requiring local anesthesics. Six of these, grouped in threes, are semi-enclosed. Folding partitions make full enclosure possible.

Of the three remaining operatories, the largest is equipped with an X-ray machine. Centrally located to the other operatories, this room is lead-lined. The demonstration operatorio is equipped for cases requiring general anesthesia as well as local. So is the adjacent operatorio (upper right). In addition, the demonstration operatorio is designed for closed-circuit TV. A glass-enclosed gallery can be used for observation of treatment procedures, or as a control booth for TV.

Both of the operatories equipped for general anesthesia are located adjacent to their supporting facilities. A scrub-up area is provided at the entrances. Nearby is the recovery area containing bunks and toilet facilities. A glass-partitioned nurse's station permits observation of patients. Also conveniently located are the sterilizing and sterile supply rooms, which serve only this clinic. Of the two rooms provided for storage of medication, one is used for narcotics and other medicines which must be kept locked.

Ancillary Facilities.—Student facilities include a locker room with toilet, located near the secondary exit from the main operational area. The combination graduate student study area and laboratory accommodates four students. It contains desks, lockers, and a laboratory bench with a sink and electrical outlets. Locating the two administrative offices at the entrance to the clinic permits greater control and accessibility. A departmental research laboratory is provided, as in other clinical departments.

A patient waiting room seating 16 people would be adequate in a clinic of this type. Toilet rooms should be pro-

ORAL SURGERY DEPARTMENT

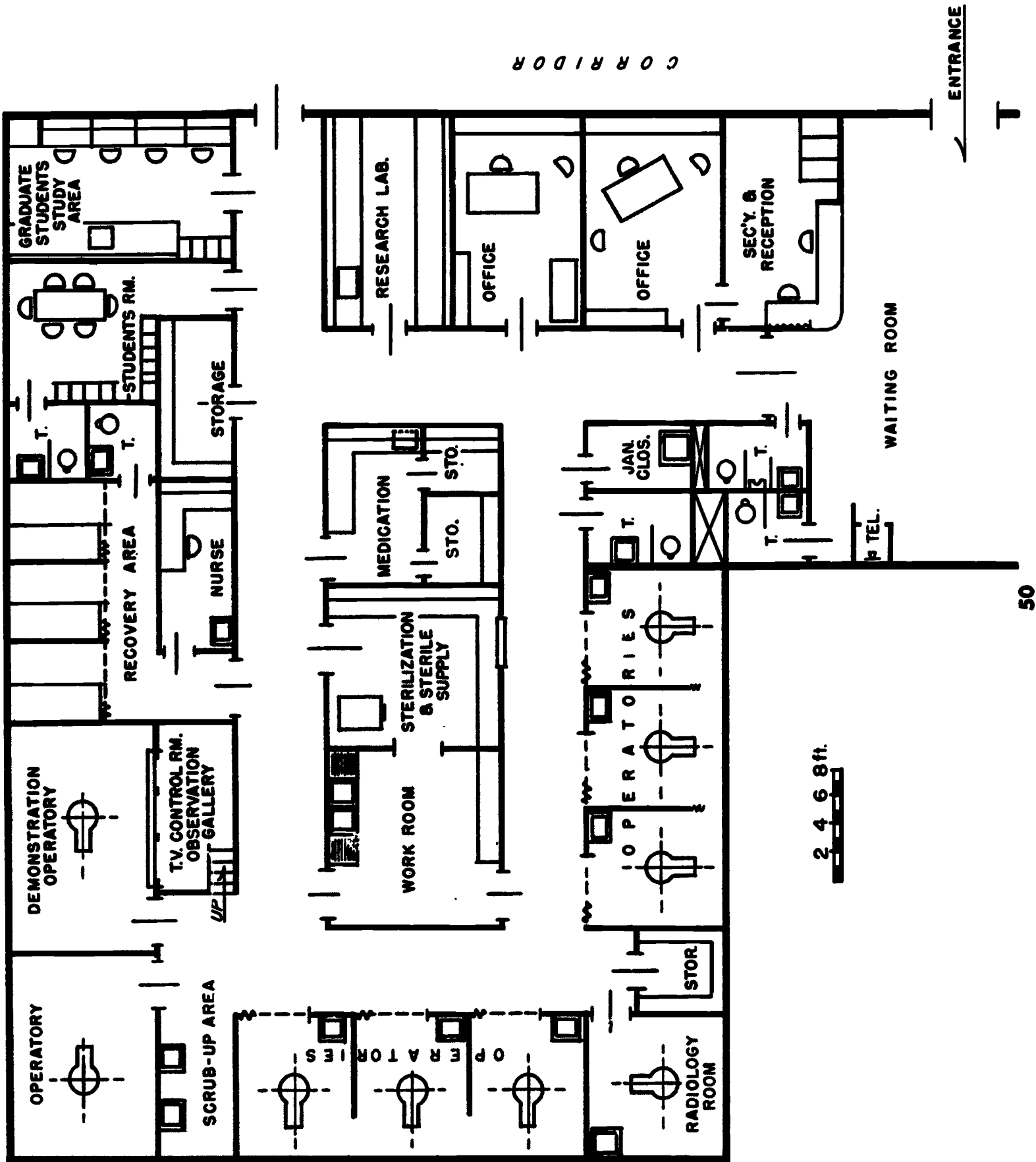

FIGURE 18.

vided nearby. Although patients would normally enter and leave the clinic through the main waiting room, a secondary exit is provided for those requiring assistance after surgery.

SUPPORTING FACILITIES

CENTRAL SUPPLY AND DISPENSING SERVICES

Although each clinic in the treatment area will have its own small supply facilities, centralized service is necessary for the receiving and distribution of bulk supplies. Locating the central service near the clinics will permit greater efficiency. In a multi-story building, stacking the smaller units on different floors will simplify the placement of service elevators and dumb-waiters.

CLINICAL LABORATORIES

In the laboratories attached to the clinics of the treatment area, the student prepares the restorations and appliances he has prescribed for his patients.

There is a great deal more variation from school to school in size and arrangement of the clinical laboratories than in those designed for preclinical training. Some schools have two general clinical technic laboratories of full-class size—one each for the junior and senior years. Some have only one, which is shared by both classes. Others have a commonly shared general laboratory, but for training purposes, they divide it into sections, each specializing in one type of clinical technic, such as operative dentistry or prosthetics. Still others have smaller separate laboratories, each attached to an individual clinic specializing in one particular type of dental treatment.

Despite the variety of arrangements currently used, most schools today believe the provision of two large general laboratories of full-class size—one for the juniors, one for the seniors—to be the most effective, and for a simple reason. Here, as in the preclinical laboratories, it is the only arrangement that permits every student to have his own permanently assigned laboratory position.

However, schools which cannot afford two full-class laboratories may make one well-equipped general laboratory serve adequately by careful analysis of clinic and laboratory schedules. Small separate laboratories in each of the special clinics are also a possibility.

In most schools, by virtue of student rotation in clinics, general laboratory occupancy during peak periods will average about 40 percent of the combined junior-senior enrollments. No comparable average is available for occupancy of laboratories attached to special clinics, but relatively low percentages of students will be working in periodontics, pedodontics, and operative dentistry laboratories, while the occupancy in crown and bridge and prosthetics laboratories will be higher. Whatever final arrangement they choose, however, schools should make every effort to see to it that each junior and senior student, whether or not he can be given an assigned bench position, is at least provided with assigned, individually locked cupboards and supply drawers.

If the full-class laboratory for each of the upper classes can be provided, the design and layout will be approximately the same as that of the freshman-sophomore preclinical laboratories. Though no special demonstration position need be set aside, facilities for ETV should be included.

The processing laboratory, which contains special equipment such as heavy duty ovens, boilout tanks, and packing and curing units, must be large enough to accommodate not only students but the dental laboratory technicians employed by the school.

Layout for special laboratories will, of course, vary. Figures 19, 20 and 21 show possible arrangements for both general and special laboratories.

FIGURE 19. Clinical processing laboratory with boilout tanks and lathes.

FIGURE 20. Benches in an orthodontic laboratory designed for graduate work.

FIGURE 21. Ovens and centrifuges used in casting metal restorations.

13 CLINICS: SPACE ALLOCATIONS AND RELATIONSHIPS

The pattern of patient movement dictates to a marked degree the relationship of one clinic area to another within the space assigned to the total clinic complex. For example, the radiology and diagnostic clinics should adjoin, and both should be adjacent to the reception and screening area. All of these facilities should be convenient to the general clinic, where the majority of patients are referred.

In the planning of the special clinics, the location of oral surgery is a major consideration. Because completely aseptic conditions must be maintained at all times in oral surgery, it should be isolated as much as possible within the clinic complex.

Though the flow of patient traffic may have the greatest influence on overall clinic layout, the design of the physical plant also affects internal space relationships. Where multi-storied buildings are planned, for example, similar facilities located on separate floors should be stacked. Waiting rooms located directly above one another can use the same communication tubes to transmit patient records. Vertically aligned clinic supply areas can utilize the same dumbwaiter or service elevator.

WHICH PATTERN OF ORGANIZATION?

Concurrently with the analysis of space relationships, the planning committee must decide how the clinics will be organized and whether open or cubicle clinics will be provided.

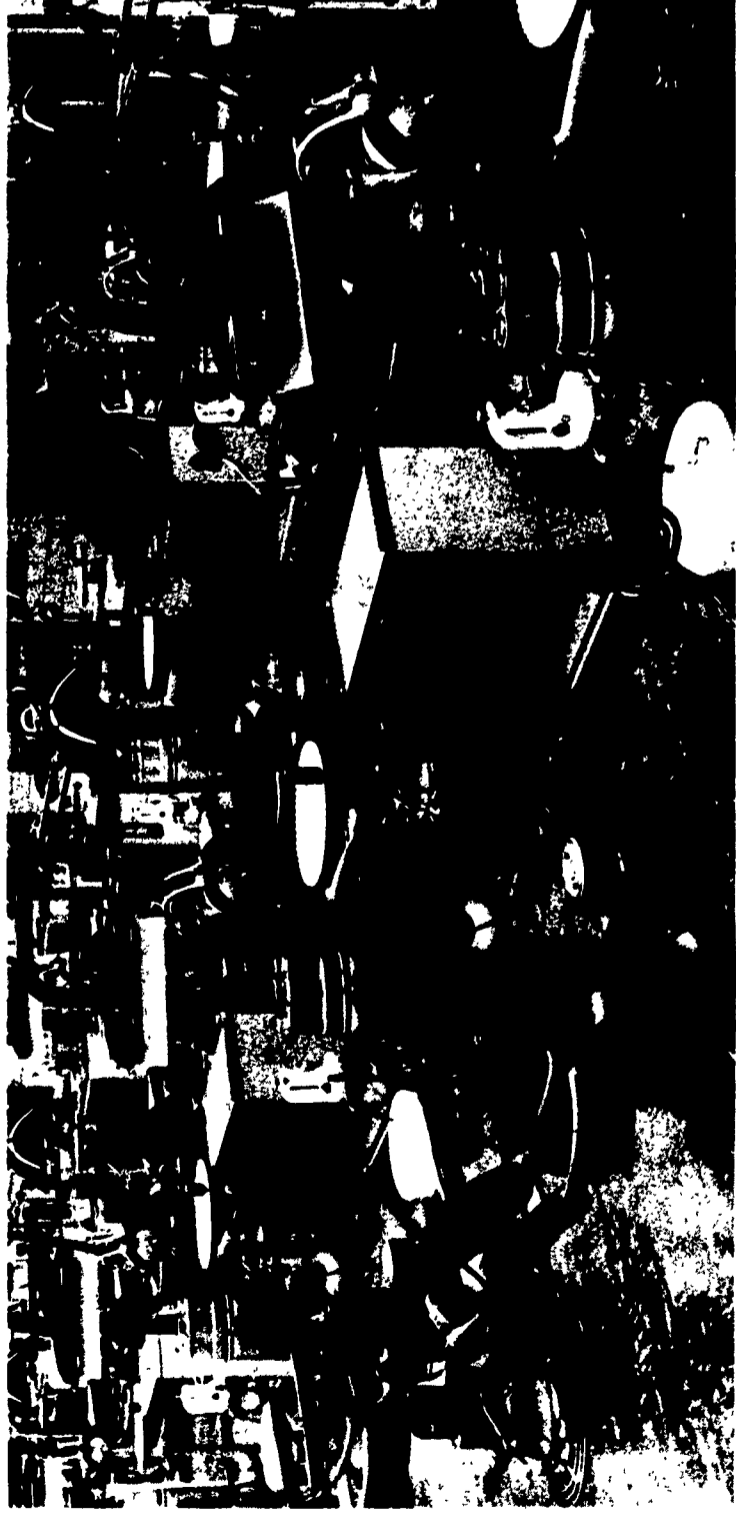

FIGURE 22. An open clinic, with stands for students' instrument cases.



FIGURE 23. The cubicle clinic, favored by many dental educators.

A CHOICE BETWEEN OPEN CLINICS AND CUBICLES

Traditionally, dental school clinics have been open, unpartitioned areas, with rows of dental chairs, or work stations, grouped throughout the room (fig. 22). In cubicle clinics, by contrast, each work station is either fully or partially enclosed (fig. 23).

Here again, past patterns appear to be changing. Dental educators today favor the adoption of the cubicle clinic. Although the open clinic is cheaper to construct, requiring less floor space for a given number of chairs, the cubicle clinic offers advantages which offset the additional expense.

Older dental schools have usually provided for specialized dental services in designated areas of the general clinic. The maintenance of separate special clinics is a relatively recent development, and one that dental educators strongly support. Grouping facilities for related dental services in a separate clinic assures a more efficient use of equipment and of auxiliary personnel. And because supplies and equipment are available where needed, traffic through the clinics is reduced.

OPEN CLINIC

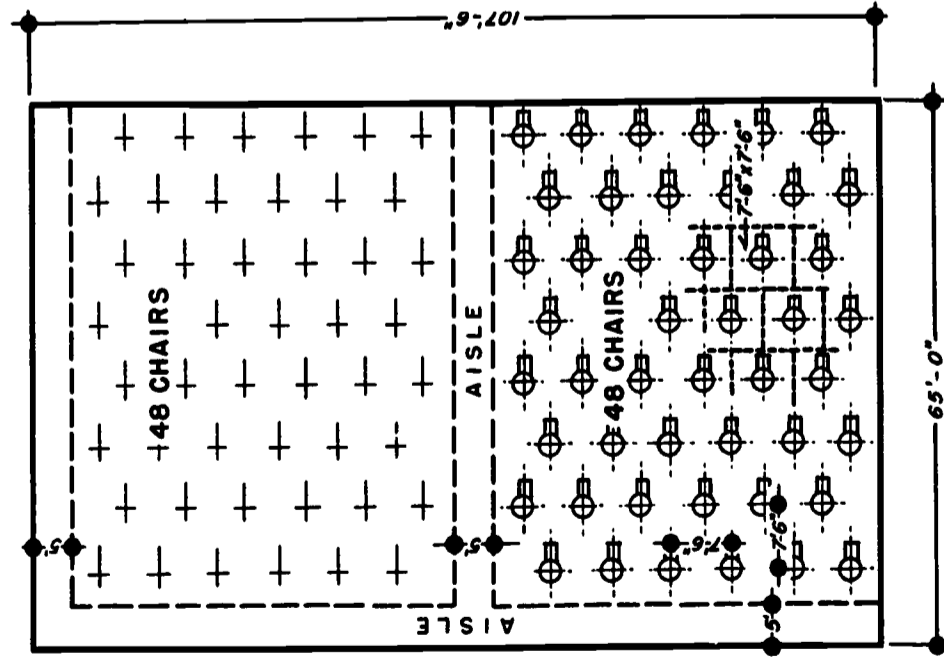

96 CHAIRS
69875 sq. ft. (728 sq. ft./CHAIR)

FIGURE 24A.

CUBICLE CLINIC

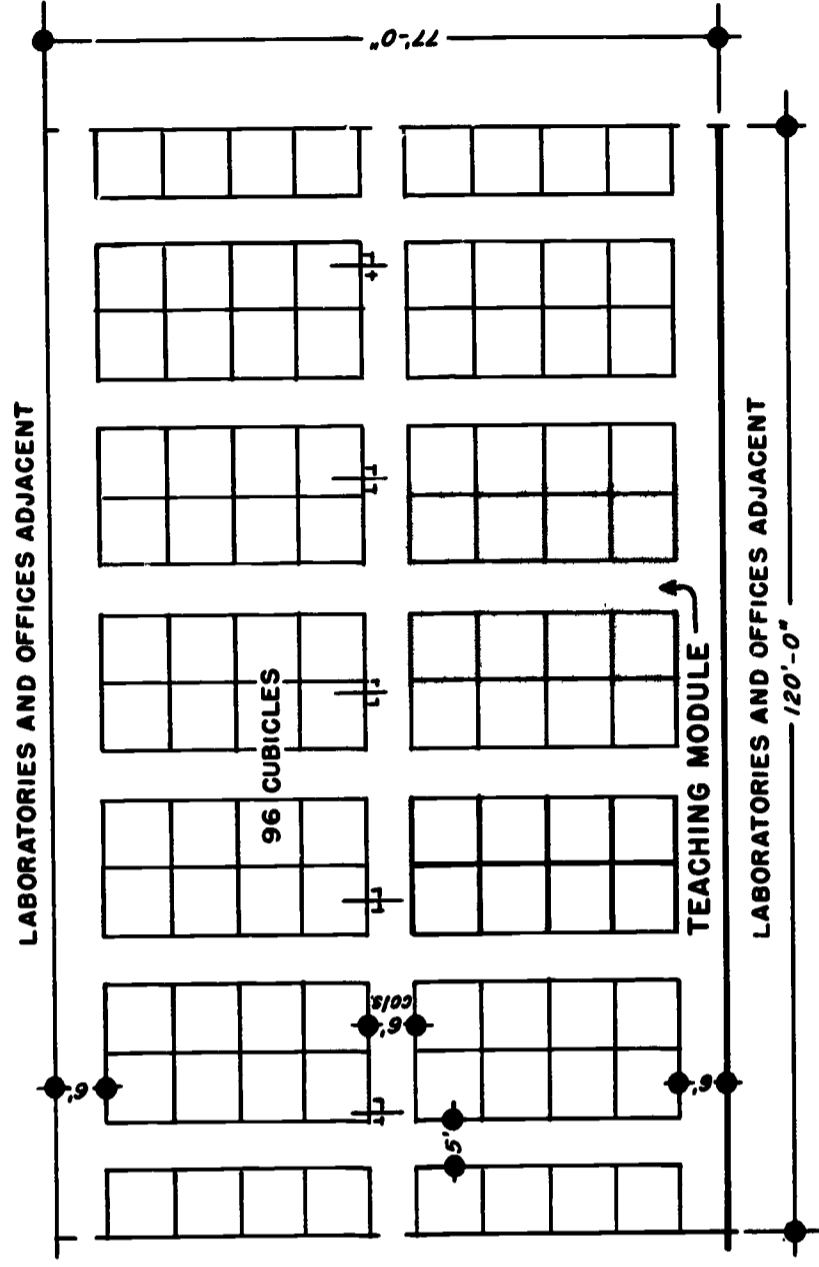

9240 sq. ft. (96.3 sq. ft./CHAIR) CLEAR SPAN - NO COLUMNS
9360 sq. ft. (97.5 sq. ft./CHAIR) CENTER ROW OF COLUMNS

FIGURE 24B.

The privacy of the cubicle, a factor appreciated by patients as well as students, and the overall atmosphere of the cubicle clinic engender self-confidence and efficiency on the part of the student.

PLANNING THE CUBICLE CLINIC

Where the choice of cubicle clinics is made, a number of problems must be resolved before planning advances if the most efficient layout of the clinics is to be assured.

Structural Problems

As noted in chapter 7, clinic planning must be coordinated with structural and mechanical planning. Bay size and column spacing, for example, can materially affect cubicle and chair layout and the effective use of floor space. Where the location of columns will adversely affect layout, long-span construction should be considered.

In figure 24A, the location of the column in the center aisle reduces the usable width of the room by approximately 1 foot. To obtain the same amount of usable floor space that long-span construction would have provided, the width of the room must be increased by 1 foot. In figure 24B the enclosed space between the columns is used only to house branch utility lines. In instances such as these, the added expense of long-span construction should be weighed against the cost of columns and additional floor space.

Staffing Ratio

Early decisions about the ratios of faculty to students will permit the architect to lay out the cubicles in teaching units of desired size (see figs. 24A, 24B, 25, and 26).

Influence Of Dental Assistants

In planning for cubicles, the committee must determine whether chairside assistants will work in all or only a portion of them, since cubicles accommodating the student-assistant team must be narrower and deeper than those in which a student works alone. The size (7'6" x 7'6") and the arrange-

ment of the cubicle in figure 27, with the instrument panel at the right of the operator, is satisfactory for the dental student working alone. It is not practical for the student working with an assistant because the instrument cabinet and the sink are not readily accessible to her.

The cubicles in figures 28 A and B are planned for utilization of assistants. The cubicle in figure 28A, which is 6'9" x 9'2", is slightly narrower and deeper than the one in figure 27. The added depth of the cubicle in figure 28A permits the location of the instrument cabinet and sink at the rear of the cubicle, convenient to the operator and the assistant. Figure 28B is another variation, adaptable to the 4'8" planning module.

VARIATION OF CUBICLE CLINIC

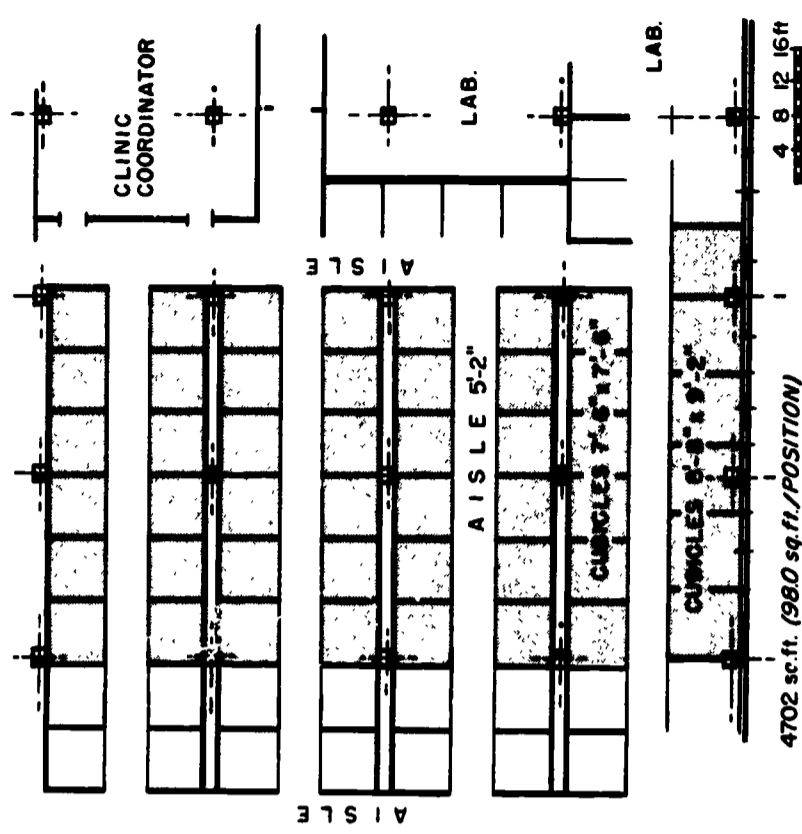

FIGURE 25.

A cubicle clinic designed for utilization of auxiliary personnel is illustrated by figure 26. The location of the main and secondary aisles permits the instructor to move from one work station to another without retracing his steps.

Cubicle Dimensions

Cubicles in existing dental schools range in size from 6'4"x7' to 7'8"x9'6". Where dental assistants will be used, a cubicle of 6'9"x9'6" is desirable. For students working alone, a cubicle of 7'6"x7'6" is adequate.

Cubicles may be either partially or fully enclosed. A partition height of approximately 5 feet is recommended for most cubicles (fig. 29). This provides privacy, yet allows for supervision and gives an impression of spaciousness. A 4-foot partition topped by a 1-foot high translucent plastic panel may be used. Allowing an open space between partition and floor facilitates cleaning. However, one or two fully enclosed cubicles are desirable in every clinic.

CUBICLE CLINIC FOR UTILIZING DENTAL AUXILIARY PERSONNEL

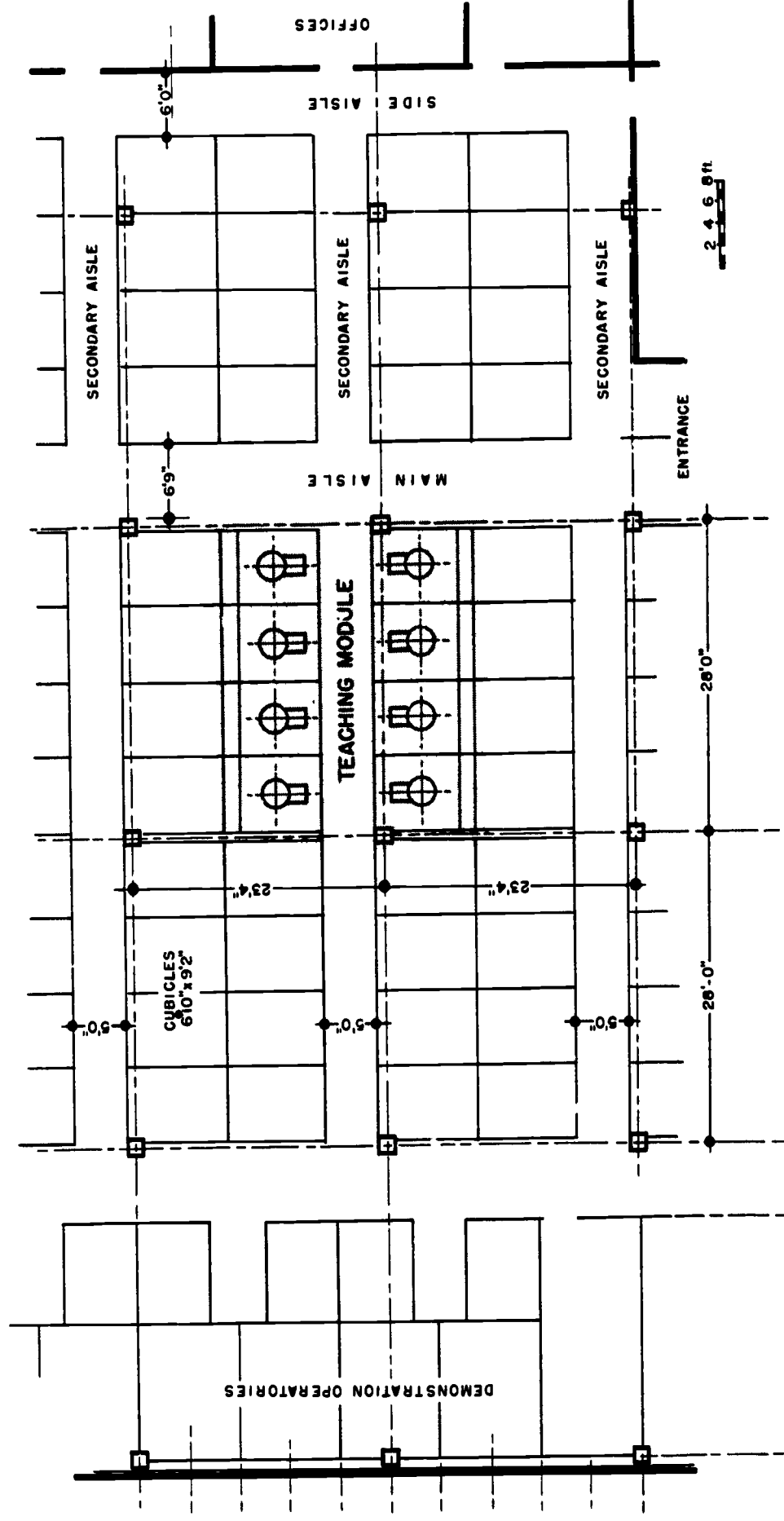

FIGURE 26.

DETERMINING THE NUMBER OF CLINIC POSITIONS

Because the number of hours scheduled in the different clinics varies so widely from school to school, every school must decide, on the basis of its undergraduate requirements, how many work stations each clinic will need. Facilities in each special clinic are planned to accommodate blocs of students rather than an entire class. The number of students in a bloc will vary in different clinics, but all blocs should be planned in fractions of the student module adopted for planning other areas of the school. Groups or multiples of 4 would be practical in schools utilizing a 16-student module for planning.

For the clinics as a whole, at least two operating positions

should be provided for every entering class student—one in the general clinic and one in the group of special clinics (fig. 30). However, additional positions in the special clinics will probably be required because of scheduling problems. A school of 96 entering class students, for example, might need as many as 116 positions in its special clinics to allow for overlapping in student assignments. With its 96 positions in the general clinic, this school would therefore need a minimum of 212 clinical positions for undergraduate students alone.

Every school should also plan additional clinic positions for its graduate and postgraduate students. The equivalent of one student module is desirable in the general clinic for

A CUBICLE FOR STUDENT WORKING ALONE

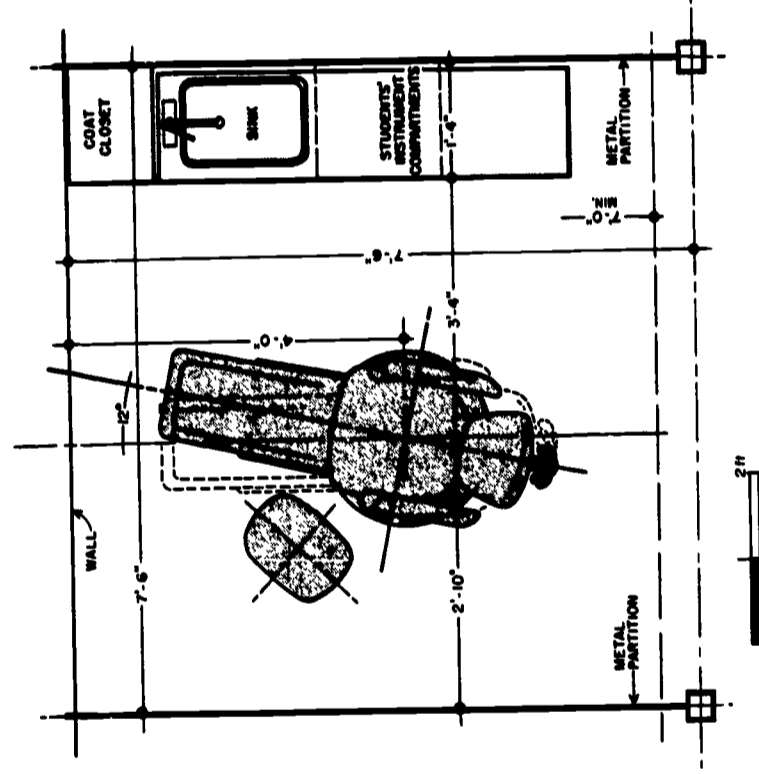

FIGURE 27.

A CUBICLE FOR STUDENT AND ASSISTANT

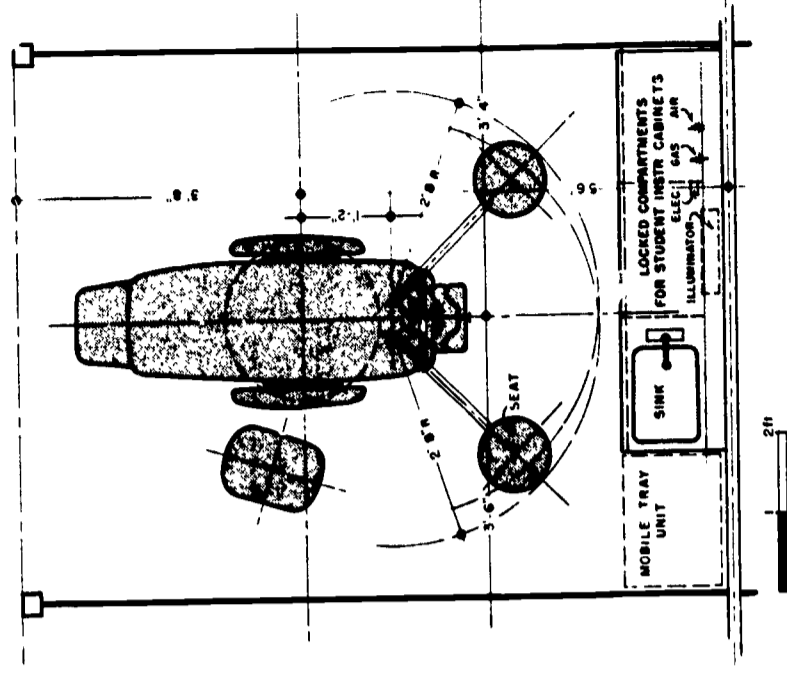

FIGURE 28A.



FIGURE 29. Cubicle clinic with low partitions where chairs face the aisle.

VARIATION FOR STUDENT-ASSISTANT TEAM

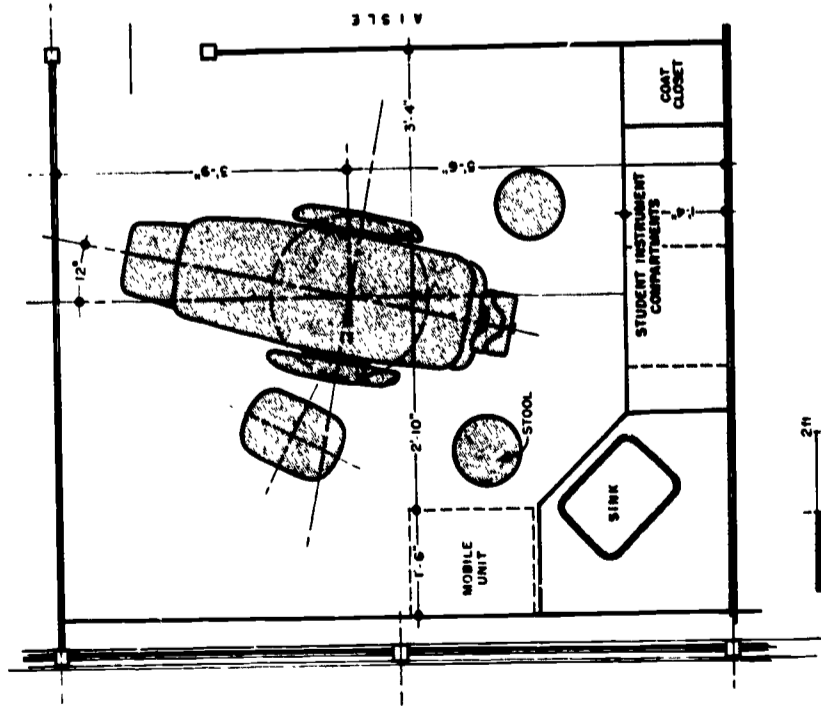

FIGURE 28B.

even a modest program of advanced study. Additional positions will also be needed in the special clinics, with the number dependent upon the goals of the school and the particular dental specialities emphasized in its graduate curriculum.

ESTIMATING SPACE REQUIREMENTS

Space allowances for each operating position will also vary in the different clinics. The diagnostic clinic will require 85 square feet per position, an allotment also sufficient for oral surgery. In the radiology clinic, 115 square feet per position should be allowed, and in the clinic for the chronically ill and handicapped, 125 square feet. For other clinics, an allowance of 100 square feet per student position should be adequate.

These allotments are generous, even after allowing for partitions and the use of assistants. In open clinics, slightly less space will be required.

Space allowance for some of the supporting facilities of the clinical departments will be fairly standard. For demonstration operatories, for example, a uniform allowance of 200 square feet each may be used. The size of patient waiting rooms and their seating capacity, on the other hand, will be determined by the number of chairs in the clinic and the resulting flow of patients. The specialized facilities required for the functioning of the individual clinics will also demand different amounts of space, and each should be analyzed carefully.



FIGURE 30. Cabinets are sometimes used to separate work stations in an open clinic.

COMMON FACILITIES FOR TEACHING AND RESEARCH

- 14. INSTRUCTION ROOMS, STUDY AREAS AND LIBRARY FACILITIES**
- 15. EDUCATIONAL TELEVISION AND OTHER VISUAL AIDS**
- 16. SUPPORTING SERVICES FOR LABORATORIES AND CLINICS**

Part

14 INSTRUCTION ROOMS, STUDY AREAS AND LIBRARY FACILITIES

The changes underway in dental education will bring certain alterations in the allotment and utilization of instruction and study space.

INSTRUCTION SPACE

Although a subject by subject analysis of the scheduling demands of the undergraduate curriculum provides the basis for planning for instruction space, programming committees must also consider the demands that the growth of graduate and postgraduate programs and the provision of training for auxiliaries will make. They will find, too, that new modes of instruction bring changes not only in the relative need for different types of space—small group teaching requires more seminar rooms, for example—but in the provision of special features within space of a given type. All instruction rooms in new schools will undoubtedly be planned for a built-in versatility, accommodating a much greater use of ETV and other visual aids, for instance.

In its concern for the new, however, the committee must not slight the old. Acoustics, lighting, ventilation, comfortable and adaptable seating arrangements, even the provision of chalkboards—which apparently are always too small and too few—all deserve thoughtful and unhurried consideration.

SEMINARS

The seminar is a room especially planned to accommodate small group instruction for 16 students or less, usually at an advanced level of training. Today, in most dental schools, seminars are used not for regularly scheduled classes, but for clinical diagnosis sessions and for impromptu conferences between students and instructors. However, expan-

sion of graduate and postgraduate departments will undoubtedly demand increased scheduling of formal seminars, and care should be taken to provide enough rooms to house them.

In most schools, one or more seminar rooms will be needed for the use of each basic science department—at least one for instruction and perhaps one for departmental conferences. Although basic science departments in a small school might pool their facilities, the growing demand for rooms of this size, the possibility of an unforeseen need to expand, and the relatively small cost of these rooms suggest that a planning committee would be wise to be generous in programming for them.

In the clinical facilities of most schools, each of the special clinics will need one seminar room for treatment planning and consultation, and the general clinic will need more than one. In programming, a reasonable standard for the general clinic would allow 4 rooms for a class size of 96, increasing or decreasing the number by 1 for each 16-student module added or subtracted.

Allow a minimum of 300 square feet for each seminar room, with increments of 75 square feet for every 4 students beyond the 16 accommodated in the standard room.

Seating arrangements in seminar rooms are a matter of choice. Usually the instructor and his students sit around a central table but some seminar rooms are furnished with standard tablet-arm chairs. Unitized folding tables and folding chairs permit maximum flexibility in seating arrangements, however, and their use is increasing, especially in the seminar room used for showing slides, 16mm films and other visual aids. If it is so used, a small adjoining room for storage of visual aid materials is also helpful. A seminar, like any other instruction room, should be equipped with a chalkboard.

CLASSROOMS

Too large for seminars, too small for whole-class instruction, the traditional classroom is seldom practical for the

instruction of undergraduate dental students. But here, again, usefulness will increase as electives are added to the undergraduate curriculum and, more particularly, as graduate and postgraduate programs expand. Classrooms are also well-suited for the instruction of dental assistants, hygienists, and technicians, since their classes are often intermediate in size.

For greater potential use, classrooms may be designed to accommodate two or three 16-student units and equipped with movable partitions so that they may double as seminar or conference rooms. However, movable partitions seldom deaden sound between two rooms enough to make this a fully satisfactory teaching arrangement. At best this is a makeshift but possibly useful standby arrangement.

LECTURE ROOMS

The largest of the standard instruction rooms, lecture rooms are generally considered common space, available to two or more departments or schools.

Although they accommodate a minimum of 50 people, all lecture rooms need not have the same capacity. The smallest should, however, seat at least a full class, plus an overrun of 20 percent. If the school expects a later expansion in class size, lecture rooms should be planned from the beginning to accommodate it, and the 20 percent overrun allowance should also be based on the larger figure.

A good rule of thumb is to provide seating capacity for 1 additional 16-student module beyond class size in schools with 96 ECS. An allowance of 12 square feet per seat (roughly 200 square feet for a student module of 16) is sufficient to permit an adequate aisle on either side of the seating area and, in a large lecture room, a center aisle as well.

A minimum of three lecture rooms should be provided, one for use of the basic science departments and located near them, one for clinical and preclinical instruction and accessible to the clinics, and one for special courses or for multiple use. In the school which will have no auditorium, the multiple-use lecture room might be designed to provide

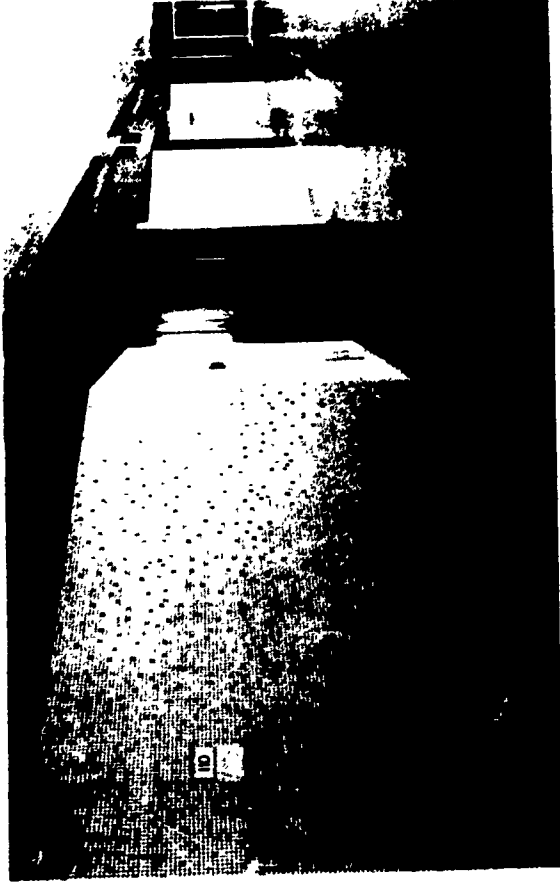

FIGURE 31. *Wide, well-lighted corridor in a modern dental school. The splayed walls reduce sound reverberations within adjoining lecture rooms.*

2½ positions per ECS. This will be large enough to accommodate all clinical students as well as the full-time clinical faculty, with some reserve space for others who might wish to attend lectures or other special meetings held in this room. All lecture rooms should be located so as to minimize noise and traffic congestion in the corridors (fig. 31).

Layout.—It may be difficult to decide whether the lecture room should be long and relatively narrow, like the usual hall, or wider and shallower, like an amphitheater. Because of its wide viewing angle, the amphitheater is not particularly suitable for the showing of slides and films. On the other hand, instructors favoring the chalk talk technique often dislike a long room. TV monitors can be used in either type.

Every lecture room should be equipped with a large chalkboard; a minimum of 12 linear feet is recommended. If, because of the size of the room, a raised platform is provided, it should be long enough to extend 2 feet beyond each end of the chalkboard. Projection screens which can be automatically lowered and raised may also be a part of the permanent equipment.

The floors of lecture rooms should be sloped or terraced slightly to provide a good view of the chalkboards and projection screen. Some larger lecture rooms are split level, or have a balcony. Whenever possible, students should enter from the rear.

Furnishings.—Fixed or movable tablet-arm chairs, or auditorium seats equipped with tablet arms, are commonly found in lecture rooms. If the latter are used, the aisle seat at the left of each row can be fitted with an outside tablet arm for the use of left-handed students. Writing counters with individual seats are also frequently used.

Some of the newer lecture rooms have demonstration tables equipped with water, gas, and drains, but little need has been found for them. Demonstrations requiring utilities are usually given in laboratories. Outfitting lecture rooms for such a purpose, particularly in an era of television, is probably a needless expense.

Figure 32 is a lecture room typical of recently constructed schools. The room is equipped with 150 fixed seats. Its walls are paneled with mahogany veneer, while the ceiling and rear wall are acoustically treated. Projection screen and chalkboard are electrically controlled. Dimming controls for lights are placed at both the front and rear of the room.

Auditoriums.—For schools that have ready access to them, auditoriums sometimes serve as lecture or examination rooms. As a rule, however, programming committees will find it difficult to justify a large auditorium solely for the use of a dental school, since it is generally more economical to rent a hall for occasions, such as graduations, which require large seating capacity. If, on the other hand, several schools are located together, as in a health center, and no other university auditorium is available, the programming committee should consider the practicability of including one.

If an auditorium is planned, it should be located on a ground floor. Direct entry from the outside is necessary, because the auditorium will often be used by the public when the remainder of the school is closed. Seating capacity

should be sufficient to accommodate students enrolled in every program of the school as well as the total faculty.

Auditoriums must have public toilets and cloak rooms; a small lounge off the foyer is advisable. Areas for the preparation and storage of demonstration materials should be provided backstage, as should a toilet room.

Acoustics and lighting are of particular importance in auditorium planning.

AREAS FOR STUDY, REFERENCE, AND RESEARCH

Two other types of accommodations that are beginning to receive greater emphasis in dental school planning are special study places or study cubicles for individual students, and better equipped, more adequately stocked dental libraries. Needs, here, cannot be determined by class schedules. The number of individual study places or cubicles and the seating in libraries must be measured by total undergraduate and graduate enrollment.



FIGURE 32. Lecture room equipped for ETV.

The size and content of the dental library collection permits no automatic assessment, but one thing is certain: students and teachers without access to adequate reference libraries are at a serious intellectual disadvantage, and graduate studies and research, in particular, will suffer.

STUDY AREAS

In most existing dental schools, the only available study places are those in library reading rooms—an arrangement generally considered unsatisfactory. The library is often located outside the dental school proper; places are catch-as-catch-can, rather than permanently assigned; they are available to students only during library hours. Over half the dental schools therefore report a need for adequate study places. Places for first and second year students should probably be located near the basic science laboratories, and those for third and fourth year students near the clinics. If possible, they should be so situated that students will have access to them at all times, even when the rest of the school is closed.

Space.—About 19 square feet per ECS should be allowed in planning standard study places for a school providing one study place for every two students. This type of study place can be in a common room, and is usually unassigned. However, some schools may prefer the partially partitioned cubicle. Requiring approximately 48 square feet per student position, the cubicles are furnished with a desk and chair, a coat locker, and storage space for books, microscopes and school supplies (fig. 33). Because a cubicle is permanently assigned to each student, space requirements are based on the total enrollment.

LIBRARY FACILITIES

A good library, well stocked and adequately staffed and equipped, is indispensable to a dental school. But whether the library should belong solely to the dental school or be part of a larger medical school or university library is a matter about which dental educators themselves do not agree.

About half of the present schools do have their own libraries; the remainder share facilities with other schools in the university. In either case, all schools are satisfied with things as they are and see no need for a change.

Collection Size.—It is equally difficult to establish any definite criterion for determining the number of volumes an adequate library should contain. The largest existing dental school library has more than 25,000 volumes and is already short of shelf space; other libraries, though located in dental school buildings, are so small as to suggest that they are supplemented by additional library facilities elsewhere.

In assessing their own school's needs, programming committees will undoubtedly consider the availability of other campus libraries; however, this assessment should also take full account of the adequacy and accessibility of such facilities. If they are so far removed from the dental school that students and faculty are deterred from using them, they are of little value.

Should the committee decide that a separate library is necessary, it must provide sufficient facilities and an adequate staff, and it will be well-advised to consult with a competent library administrator early in the planning stage. The following guidelines, though general, may be helpful.

Reading and Study Rooms.—The main reading room should accommodate from 25 to 50 percent of the total number of students. Reading room exits should be controlled by book charge-out or loan desks, and the card catalogue and circulation desk should also be nearby (fig. 34).

Carrels.—Unenclosed desk areas of about 12 square feet— are useful for individual study and should be available in the ratio of 1 for every 10 students. Small study rooms reserved for graduate and postdoctoral students are also an advantage. Either they should be sound-proofed or located far enough away from the main reading room to permit students to use typewriters without disturbing others.

Microfilm.—Auxiliary facilities such as a microfilm reading room, a sound tape room, and a rare book room are

FIGURE 33. Individual study cubicles give students a private, assigned study area.

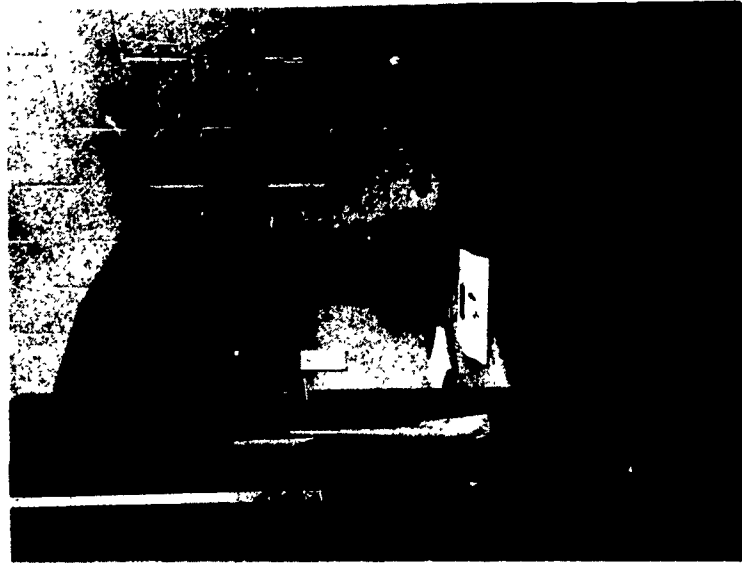

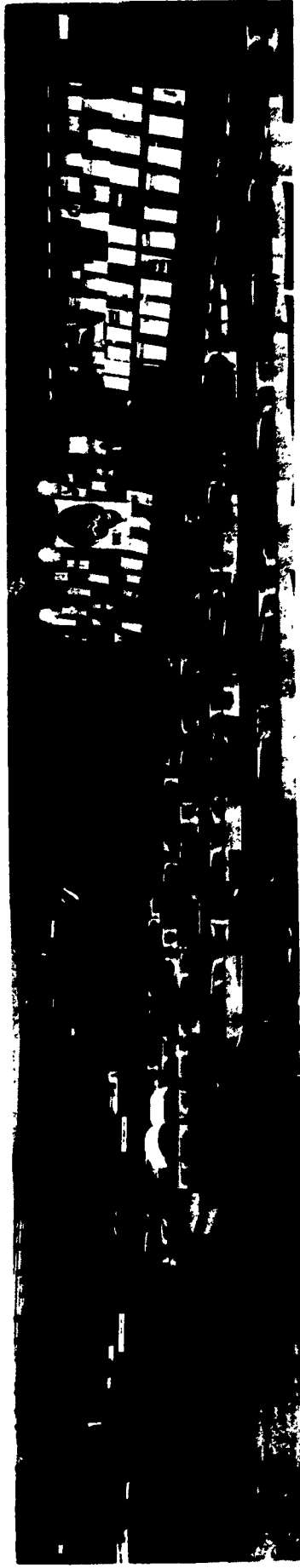

FIGURE 34. *Library reading room for dental students.*

also desirable. The microfilm reading room is particularly recommended as an effective way of providing good library service for a large number of students. Microfilm copies of rare or out-of-print texts offer an excellent means of augmenting standard shelf stocks.

Stacks.—Stacks should be arranged to facilitate both storage and use of books. The stacks should be located as close to reading rooms as possible, preferably at or below the level of the main reading room.

Stack area varies in proportion to volumes. Generous allowances should always be made for future expansion. Stack sections are usually 3 feet in length and 7'6" in height, with a shelf depth of at least 10 inches. One single-faced section 3 feet long will accommodate approximately 100 volumes. Service aisles between stacks should be at least 3 feet wide, and the main aisles at least 3'8" wide. A microfilm room for processing and storage may be associated with the stack area. Storage is always a problem for libraries. Allowances for storage of additional materials must be made in the initial planning.

Other Facilities.—Acquisition and catalogue rooms should be near the public card catalogue and have direct access to the stacks.

Offices should be provided for the head librarian and an assistant, with the head librarian's office accessible both to staff rooms and to readers. Storage space for office supplies should be available.

Air conditioning seems essential not only for the comfort of those who use the library but also for the preservation of reference materials.

A library stocked with 25,000 volumes and amply supplied with space for reading rooms and auxiliary facilities would require approximately 10,000 square feet for a school with 96 ECS.

15 EDUCATIONAL TELEVISION AND OTHER VISUAL AIDS

Although its total impact on education has yet to be fully measured, educational television (ETV) is already an important medium for instruction and demonstration. Well over half of existing dental schools now use TV to a greater or lesser degree, and the remainder would like to install it (fig. 35).

The planning of these closed-circuit television facilities and the installation of the necessary conduits, cables, and electrical outlets, a technical procedure to be discussed with an engineering consultant, cannot be adequately carried out

until the planning committee has decided upon the manner and degree to which the media will be employed. The relationship of the television department of the dental school to the other ETV facilities of the university should be considered and coordinated.

Changes and improvements are being made rapidly and dramatically in this relatively new field, and few schools can safely estimate their future TV programming on the basis of current practices alone.

In the clinical areas, instructors can use television not only in teaching students how to establish sound relationships with their patients, but in demonstrating the most complicated dental technic and intraoral procedures—and often with more effectiveness than they have previously been able to attain.

In the dental science laboratory, TV can be used for teaching dental technics. In the basic sciences, experiments can be demonstrated and microscopic specimens can be examined and studied. With TV microscopy, the instructor can shift the same camera from a view of surgical procedures to a specimen under the microscope (fig. 36).

FIGURE 35. *Demonstration operator in an ETV studio.*



The monitoring of students' work in the preclinical dental science laboratory by closed circuit television relayed to a console at the instructor's position also presents interesting possibilities. Although other visual aids will continue to have a large place in the teaching program, proponents of television are convinced that it combines the several advantages of each of the other visual aids. They state that the superiority of TV is due to several factors.

TV can immediately show whatever activity is desired without waiting for photographic or illustrative processing. It is flexible, and the angle or type of view can be quickly changed to give the student a better view. The camera can move smoothly from a total view to a closeup of a small area without losing the proper relationship (fig. 37).

Television lectures can be taped in advance, at the instructor's convenience. Taped lectures can be edited to achieve a smooth, interesting and accurate presentation. Their use frees the instructor for other more varied teaching assignments. Discussions or talks by visiting lecturers can also be taped for permanent use. The TV monitor can be viewed in a lighted room so that students are able to take notes.

FIGURE 36. *TV microscopy—a valuable teaching aid.*



The location of the ETV department should be carefully chosen to hold distribution distances to a minimum. A top floor or penthouse would be a logical location. Preferably, the visual aids department should be nearby. The studio should not be less than 1,300 square feet, completely visible from the control room (fig. 38). The ceiling height of the studio (13 to 14 feet) is another factor that must be considered in planning. One area of the studio should contain a dental operator set-up, with chair, unit and instrument cabinet. A movable (on casters) laboratory demonstration bench will be required for demonstrations of experiments in the basic sciences. Television of anatomical dissection will require a large overhead mirror. A smaller bench for dental technic demonstration, chalkboards, flip stand, and tack boards are additional requirements. Ample maneuvering area for the television cameras and operators must also be provided. Figure 39 shows an ETV department of approximately 2,500 square feet.

The control room should be elevated and built as close to the ceiling as possible for maximum visibility. Entry

into the control room should be possible without going through the studio.

Provision should be made for a film chain installation requiring a room approximately 12'x15'. Kinescope recorders and video tape recorders should be planned for in areas adjoining the control room.

The amount of prop storage space required will vary with the emphasis placed on television and on the availability of other storage areas.

The director and assistant director will require office areas for script conferences, preparation of run-down sheets and general administrative activities.

VISUAL AIDS DEPARTMENT

The increasing use of ETV has not eliminated the need for a complete visual aids department, but has increased it. Figure 39 shows a visual aids department. In larger schools, 18 to 20 square feet per ECS would provide centralized visual aids facilities for both the basic sciences and the dental science divisions.

FIGURE 37. View of ETV studio through control room observation panel.



FIGURE 38. ETV control room with program director at control console.



ETV AND VISUAL AIDS DEPARTMENTS

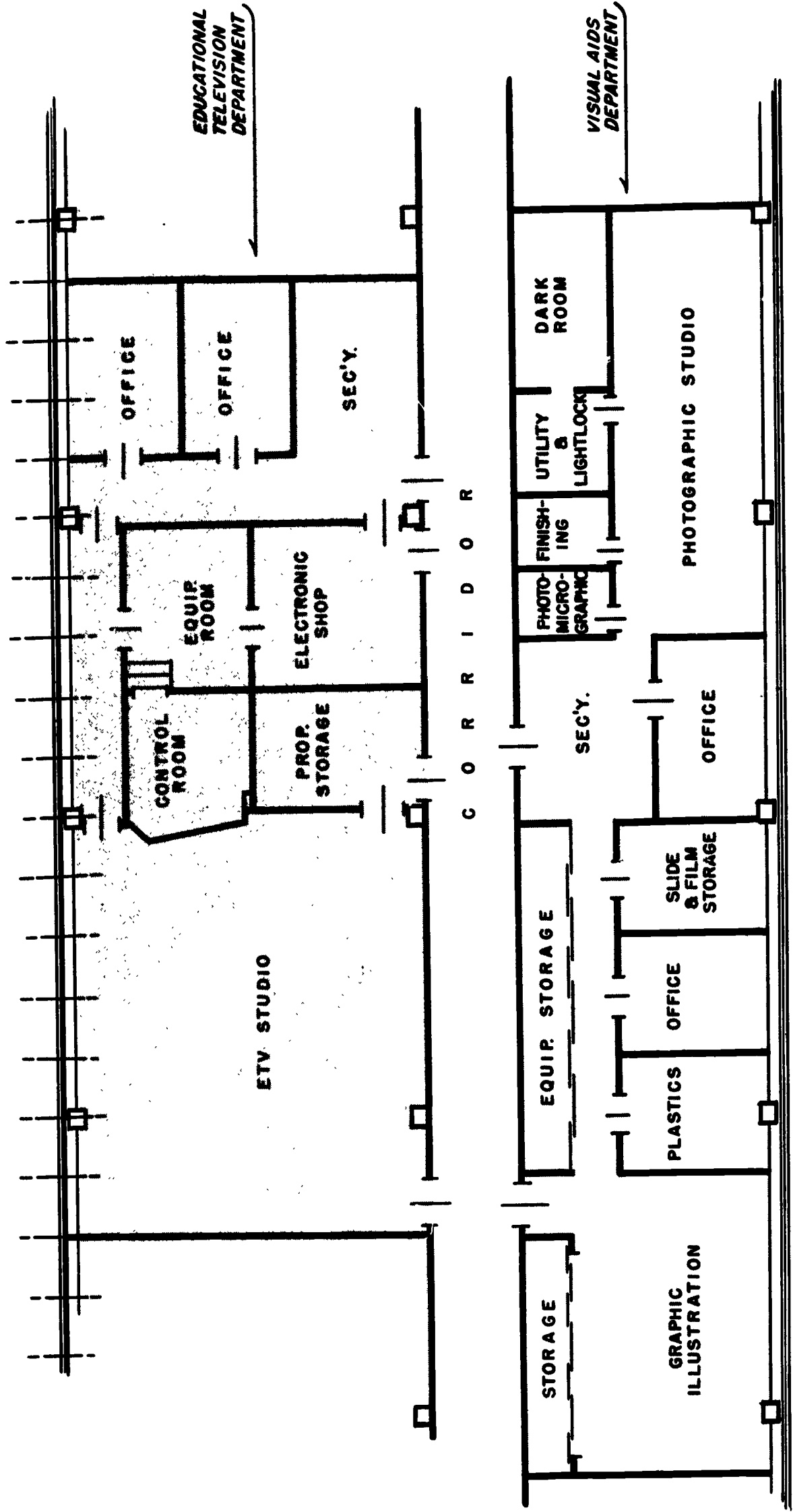

2 4 6 8ft.

FIGURE 39.

Graphic Arts.—The activities of the graphic illustration or graphic arts section include drawing, painting, and airbrush work in biological illustration, drafting of charts and technical diagrams, and general art work for displays and exhibits. Drafting tables, plan file cabinets, and a sink or lavatory should be provided.

Another room is needed for production of the three-dimensional models in plaster, wax, rubber, and plastics used in demonstrations. A work bench with sink and utilities is required.

Photography.—The room provided for the photographic section should be large enough to permit the photographing of patients, photomicrography, copying, film processing and printing, and print and slide finishing. It might also include equipment for preparing and projecting printed pages and similar opaque materials. The studio should be not less than 12 feet wide and approximately 35 feet long for making 16 mm motion pictures and for their projection.

Distribution and Storage of Visual Aids.—Administrative offices are required for the maintenance of files and cataloging of material, control of distribution and the requisitioning of visual aids materials, and adequate space should be provided for storage of slides and films and for the storage, maintenance, and operation of all projectors.

16 SUPPORTING SERVICES FOR LABORATORIES AND CLINICS

Facilities in most existing dental schools are not designed to permit centralization of all the special supporting services provided in conjunction with laboratory and clinic opera-

tions, and the consensus is that the feasibility and desirability of centralization varies markedly from service to service.

Generally, sterilization services, except for those in the oral surgery department, are centralized. Centralization of services like the maintenance of patient records and the storage of audiovisual aids is regarded as efficient and economical.

By contrast, almost every dental school now operating insists on individual departmental facilities for the storage and disbursement of laboratory supplies, equipment, and teaching aids, and they consider centralization of these services ill-advised and even unworkable.

THE ARGUMENTS AGAINST CENTRALIZED LABORATORY SUPPLY SERVICES

Departments with extensive research projects are the most strongly opposed to the centralization of laboratory supply services, listing three main points in support of their stand—the need for separate record keeping and accounting, the importance of prompt service, and the elimination of overlapping.

Records.—The increase in the amount and diversity of grants programs demands the careful recording, by department, of the purchase and use of equipment and supplies. The department must account to the university, which in turn files detailed reports with governmental agencies, private organizations, or the various fund accounts within the fiscal organization of the university itself. Centralization of the supply service would unnecessarily complicate record and accounting procedures.

Promptness.—The second point in support of departmentalized laboratory supply facilities is the importance of prompt service. Departments maintaining their own facilities have immediate access to the supplies they need. The feeling is widespread that a centralized system would almost certainly lack the staff necessary to provide fast and dependable service.

Overlapping.—In the view of many schools, departmental service facilities, since they are designed to meet specialized needs, are actually more likely to eliminate overlapping of function and staffing than centralized facilities. Schools report that where some centralized services are available, departments often do not use them; instead, they succeed in securing their own staff and equipment.

THE FEASIBILITY OF CENTRALIZED LABORATORY SUPPLY SERVICES

Although many of today's schools will continue to operate departmental service facilities, the planners of new schools may wish at least to consider the possibility of centralized laboratory supply services. Certainly, the development of a centralized system is feasible. If facilities and staffing patterns are carefully planned in advance, centralization may prove to be both a highly economical use of space and an efficient utilization of men and materials.

Figure 40 is an example of a reasonable plan for a fully centralized laboratory service. Since the operation of four-student laboratories for all basic science departments requires that equipment and supplies be in the individual laboratories prior to the beginning of a scheduled experiment, the central service facilities make delivery by placing each laboratory's equipment and supplies on trays. The trays are then placed on carts which circulate between the laboratories on regular delivery rounds.

SERVICES REQUIRING BOTH DEPARTMENTAL AND CENTRAL FACILITIES

Though most special services and the facilities they occupy are classified as either exclusively departmental, like laboratory services, or fully centralized, like sterilization services, others are generally regarded as more effective when they are administered through a system which combines some of the features of both systems. Two activities particularly adaptable to this compromise arrangement are the supply-

CENTRAL LABORATORY SERVICES DEPARTMENT

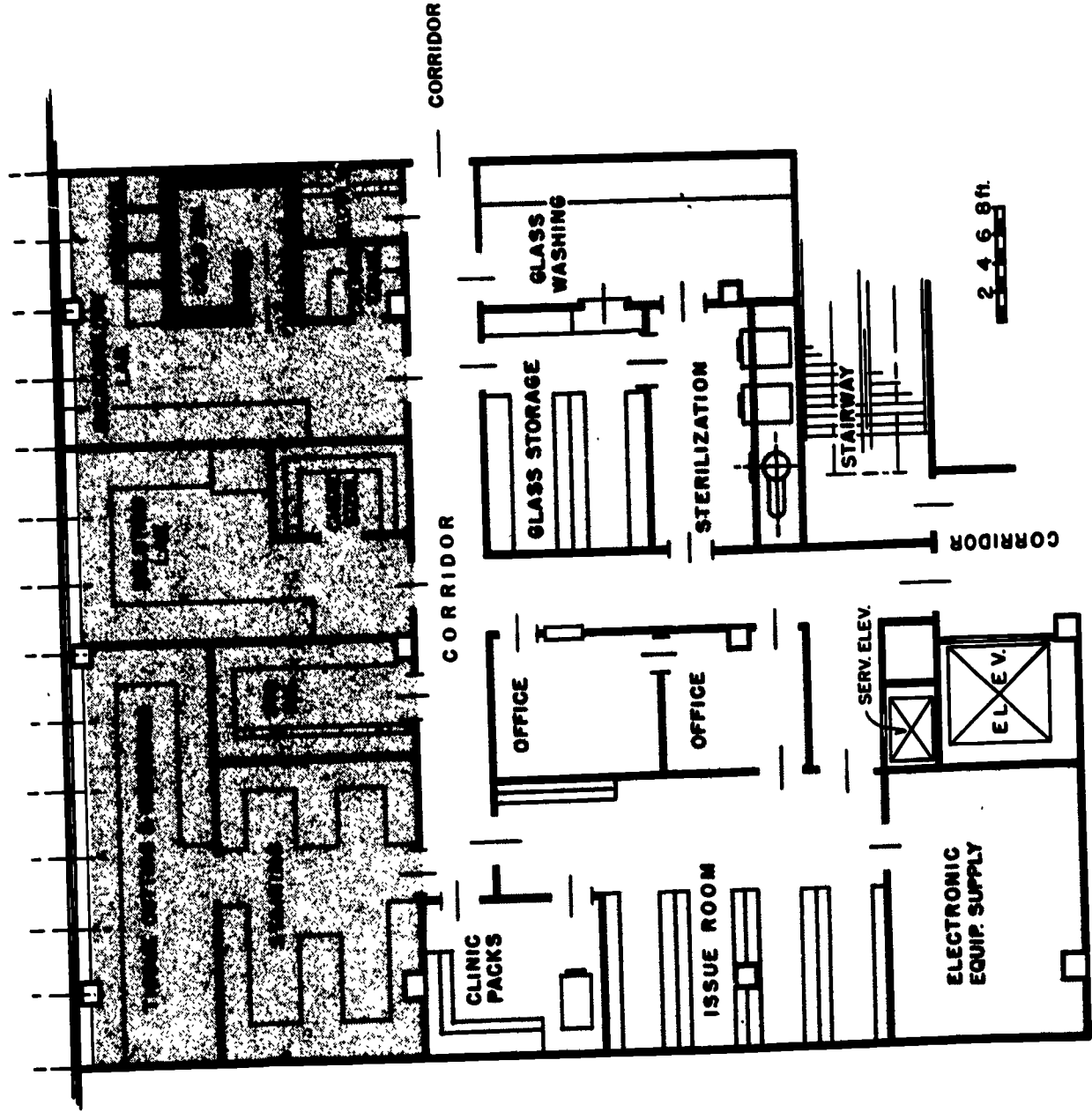

FIGURE 40.

ing of animals for experimentation and research and the servicing of the highly specialized equipment used in the various departments of a dental school.

Animal Quarters

Animals of different species and sizes are used in many basic science courses and in special clinical research projects. They are increasingly used in radioisotope research. Although holding rooms for small animals adjoin research and teaching areas a dental school must still provide one large and centrally located animal area.

To avoid the possible spread of disease, different species of animals should never be housed in the same room. Ideally, then, the central animal area should consist not of one large room but of a number of smaller ones. No room should be larger than 600 square feet—a size which will amply accommodate 32 large dog cages (fig. 41).

Space requirements for smaller animals vary, and the following table provides examples of the net footage needed:

Mice -----	7 per square foot
Guinea pigs-----	2 per square foot
Rats -----	5 per square foot
Rabbits -----	1 per two square feet

In addition to this net space, allowance must be made for corridors and vestibules within the quarters, as well as for storage.

Storage places no major demand upon available space. Adequate facilities permit the storage of bedding, house-keeping supplies, and enough food for one day near the central holding rooms. Bulk storage is not necessary, since warehouse facilities are usually available elsewhere.

Ancillary facilities of the central quarters will, however, occupy substantial amounts of space. These should include a receiving or isolation room where animals can be held for observation during laboratory tests, and at least one adjoining small laboratory and perhaps more, depending upon the size of the school's research program.



FIGURE 41. Animal quarters with cages supported on an overhead trolley system.

There should be a small room for preparing food for the animals, and a much larger area for washing and sterilizing cages. The washers and sterilizers used here must be big enough to accommodate the largest cage. (Fixed cages, which must be washed within the holding rooms, are so arranged that refuse can be washed into a gutter and then into a flushing drain.)

Other facilities found in the larger animal quarters include animal surgery rooms, equipped with their own ancillary facilities for instrument sterilization and storage, recovery rooms, an autopsy room, an incinerator room, and a refrigerated storage area. Offices for a veterinarian and for an animal keeper are also provided.

Because animals, unless carefully housed and tended, can be a source of annoyance both to the school and to its neighbors, the planning of the central animal area should not be undertaken without thorough consideration of such factors as insect and pest control, the reduction of noise and odors, and the sanitary disposal of refuse. Animal quarters should not be visible to the public, and they should be arranged so that the receiving of animals is simplified and the possibility of their escape minimized. The preferred location is on the ground level or in a properly air-conditioned basement area.

Technical Shops

Technical shops specializing in intricate and highly skilled metalwork, woodwork, and electronics are a central facility of particular value to larger dental schools. Unrelated to regular and similarly named building maintenance operations, the technical shops are responsible for the upkeep and

repair of the more complex equipment and devices employed by the various school departments. They also design and fabricate unique apparatus required for research and experimentation.

Though smaller shops of this type are attached to one of the basic science departments, the services of the central technical shops, with their larger staffs and more extensive equipment, should be available to all departments, including the basic sciences, of the dental school.

Even schools which do not require these specialized technical activities will need to provide the modest facilities required for the routine maintenance and repair of standard dental equipment, such as engines, lathes, and dental chairs. Because major repairs of this type are ordinarily made under contract, only limited equipment is necessary. A capable technician employed in such a shop can undoubtedly devote part of his time to experimental research in the improvement of dental equipment.

SPECIAL FACILITIES FOR TEACHING AND RESEARCH

- 17. FACULTY FACILITIES**
- 18. GRADUATE AND POSTGRADUATE FACILITIES**
- 19. AUXILIARY PERSONNEL**

Part

17 FACULTY FACILITIES

One of the attractions of teaching as a profession is the opportunities it offers scholars for independent research and study. Yet in many dental schools today, faculty members have neither the time to pursue their own investigations nor adequate facilities in which to do it.

A SHORTAGE OF FULL-TIME TEACHERS

The question of adequate time is not one which can be directly solved by facilities planning. The source of the problem is the shortage in many dental schools of full-time dental educators. Of the nearly 5,500 teaching today, only about 1,200 are full-time members of dental school faculties. In consequence, too many of those who do make teaching a career have such heavy class schedules that independent research becomes a patent impossibility. At the same time, the lack of adequate facilities for research hampers efforts to recruit additional full-time faculty members.

New schools, then, need to consider the facilities required for their teaching staffs in two ways: they must plan to accommodate larger full-time faculties and they must plan the type of accommodations which, by encouraging research, will attract topflight teachers.

THE EFFECT OF RESEARCH AND GRADUATE PROGRAMS

How much faculty research and office space will be needed depends upon the emphasis the school will ultimately place upon research. For if teaching responsibilities are to be met

by faculty members who devote a part, perhaps a major portion, of their time to research, then the total number of faculty must be increased accordingly.

Faculty facilities will also be influenced by the variety and enrollment in programs of advanced study offered by the school. Like research, graduate and postgraduate programs make major demands upon faculty time, and if they are to receive the emphasis which most educators believe desirable, then additional faculty must be provided.

To make sure that these additional staffing requirements will be adequately met, programming committees should carefully review their staff projections for the basic and clinical science disciplines before attempting space allocations. Schools which plan to begin with modest programs of research and advanced study and expand them later will be wise to incorporate in their initial program the additional faculty facilities they will eventually require. The rapid growth of dental research, in fact, and its close integration in dental education suggest strongly that the generous programming of faculty office and laboratory space is essential to well-thought-out building programs.

ACHIEVING BETTER STAFFING RATIOS

All full-time faculty members need research and office facilities and planning committees will be wise to assume that the basic science activities are to be staffed almost completely by full-time members. For although about 20 percent of basic science laboratory and classroom teaching is now done by part-time faculty, this percentage will decline when dental schools offer research opportunities equal to those available in medical and graduate schools.

An extremely large percentage of faculties of dental school clinical departments are part-time. There is, in fact, just one full-time teacher for every three or four who teach part time. Most part-time instructors are dental practitioners

DEPARTMENTAL OFFICE AND RESEARCH AREA

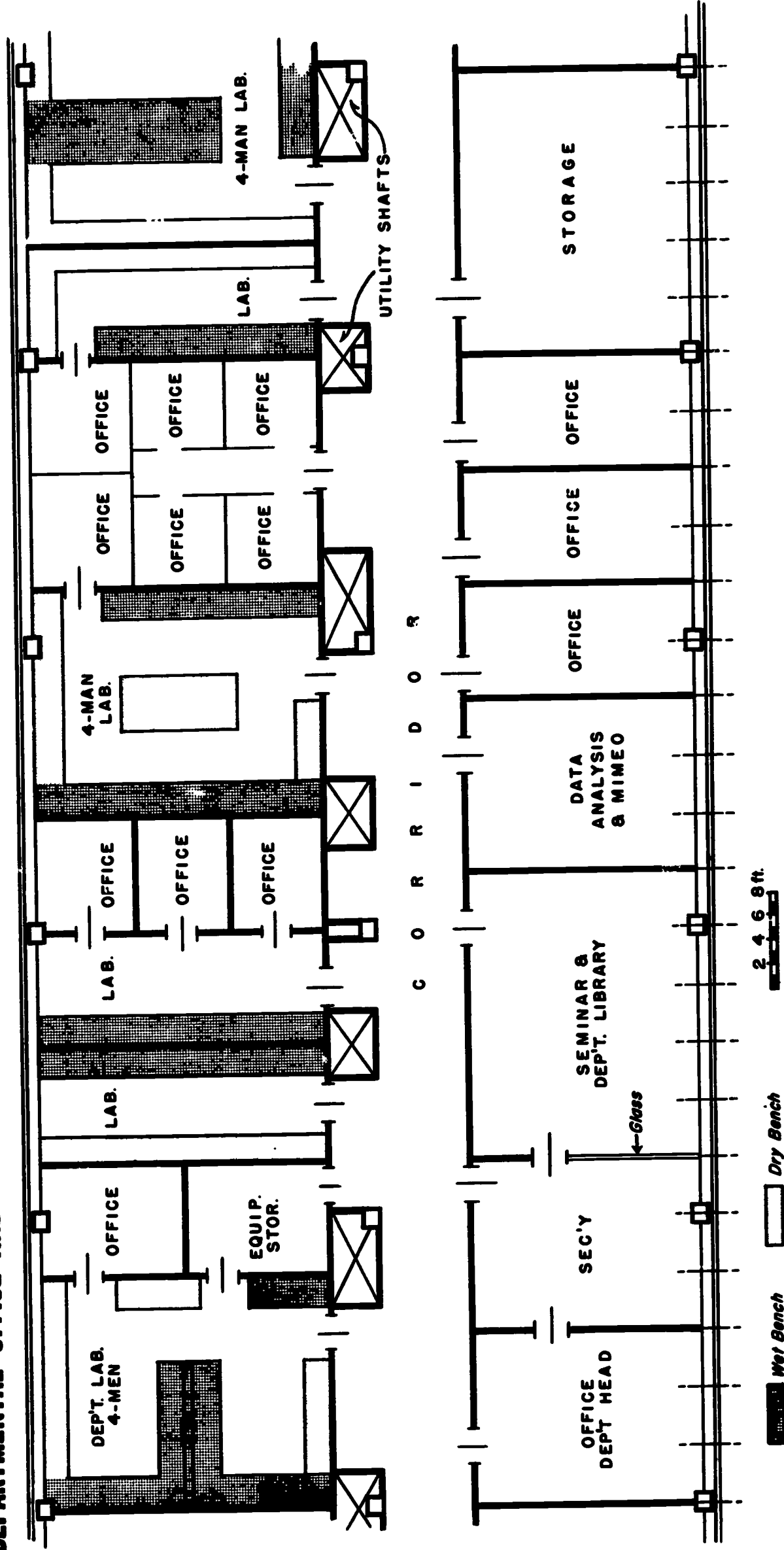

FIGURE 42.

who devote only a few hours each week to undergraduate teaching; yet they provide about two-fifths of all classroom and half of all clinical teaching.

While the intellectual stimulus the practitioner can bring to the academic scene is unquestionably desirable, dental educators generally agree that schools must alter the existing balance between practitioner and academician if undergraduate programs are to be strengthened—and that a better balance must certainly be achieved if dental schools are to fulfill their research and graduate training responsibilities.

Two full-time teachers for every one part-time teacher is the staffing goal set by the deans of dental schools when asked for their views by the Commission on the Survey of Dentistry. New schools should plan from the start to build up a clinical faculty which ultimately will achieve this ratio. Office and research space should be programmed for a full complement of full-time teachers, even though assembling them may take several years.

OFFICE FACILITIES

All faculty members will need office space which affords privacy for personal study and for student interviews, and small private offices are much to be preferred over larger shared ones. A uniform allowance of 200 square feet for each full-time faculty member will provide enough space to assure an individual office for each teacher with the rank of instructor or above as well as sufficient additional space for department heads and others with administrative responsibility.

RESEARCH FACILITIES

Space requirements for faculty research are particularly difficult to anticipate. An allowance of 100 square feet for each full-time faculty member represents the equivalent of

one small laboratory for each two teachers. This is probably a reasonable standard, provided that programmers make additional space allowances for any special project or equipment needs known to them, and provided, too, that they base their estimates upon the total number of full-time teachers the school will eventually employ.

ADAPTABILITY IN SPACE ARRANGEMENT

Even then, the need for research space may easily outgrow the allotted area, and although the allotment proves sufficient in total, individual laboratories may have to be enlarged or redesigned to accommodate additional equipment or research workers. When this occurs, office space is particularly vulnerable to encroachment or rearrangement. Modular design contributes to a school's ability to adapt the use of space to the changing requirements of research programs.

FUNCTION AND LOCATION

Faculty facilities are usually included in the area of major dental school activities, a location with obvious functional advantages (fig. 42). If they are housed separately from undergraduate areas, however, future expansion of offices and research space is simplified—a consideration of particular importance to schools whose initial building budgets are too limited to permit the inclusion of adequate facilities in the original plans. Also, if faculty facilities are grouped together in a separate area and their assignments controlled by the office of the dean, rather than by the department, the problem of transferring assigned facilities from one activity or faculty to another will be simplified. The relative merit of separate or departmentally integrated facilities should be carefully weighed before final decisions on exact locations are made.

18 GRADUATE AND POSTGRADUATE FACILITIES

Although the kind and amount of facilities for graduate and postgraduate education vary greatly, only one in five of today's schools consider their available facilities adequate even when measured by current programs and enrollments.

A greater emphasis upon graduate studies is dictated by several factors. There is first of all the realization that dental research must be strengthened, and that research for the sake of research is a traditional academic function. There is further an admitted need to train students in research methods, for a shortage of capable personnel is one of the conditions seriously retarding basic dental research.

Schools must also look to graduate programs for the solution of another serious problem—the shortage of qualified dental educators. Already forced to rely too heavily upon part-time teaching staffs, dental schools must now find additional instructors to man new schools and permit the expansion of present ones.

A far greater demand for training in dental specialties must also be anticipated. Though much specialty training is still given in postgraduate work leading to certification rather than an academic degree, a shift toward graduate programs is already underway and appears irreversible.

Obviously the expansion of graduate and postgraduate programs can be accomplished only if adequate physical facilities are available to house them. And adequate facilities will not only mean additional space, but additional space used in a different way.

Advanced study demands both a greater degree of independence for students and more individual supervision from

instructors. Dental schools will require enough research and laboratory facilities to permit graduate students to conduct extended, independent research investigations. Whether graduate programs should have separate research and laboratory facilities for their students is a matter of choice. What is essential is that there be enough space of the right kind, arranged to minimize the possibility of conflicting schedules and the disruption of graduate activity.

The assignment of study and laboratory areas for exclusive graduate use will accomplish this most effectively. How much space and in what clinical or basic science departments it will be needed must be determined by each school on the basis of its own program. Even today, schools with more than token enrollments in programs of advanced study provide accommodations for one graduate or postgraduate student for every two ECS. In the basic science departments, an allowance of 150 square feet per student will permit a 2-module office and a 4-module laboratory for each four graduate students. In the clinical departments, an allowance of 100 square feet per student will permit one small combination study and research area for each four students. Additional operatories will also be needed.

Graduate programs should also be adequately provided with study cubicles and reserved library study rooms for the specific use of their students.

19 AUXILIARY PERSONNEL

Because of the growing reliance upon the dental hygienist and the dental assistant as a means of increasing the availability of dental health services, new schools should carefully consider the provision of training for these auxiliaries.

The amount and type of auxiliary facilities required will depend upon the size of the auxiliary program and the degree to which other undergraduate facilities are utilized for them.

TRAINING FACILITIES FOR DENTAL ASSISTANTS

Although other types of schools will educate the great majority of dental assistants, many dental schools will and should offer training for them. Their courses can serve as models for those in other institutions, since the dental school is best qualified to design an effective curriculum for auxiliaries and to experiment with the content and method of classroom and laboratory instruction.

Some of the dental schools which offer courses for dental assistants will train only enough to staff the clinic projects in which undergraduate dental students are taught how to work with assistants; others will accommodate standard programs with larger enrollments. In either case, laboratory, classroom, and clinical instruction must be provided.

In a standard one-year program for dental assistants, much of the instruction can be given in a combination laboratory-classroom in which low benches are equipped with gas, air, and electricity. These laboratory-classrooms require an allotment of 600 square feet for each 16-student module. Also needed are one or two seminars.

TRAINING FACILITIES FOR DENTAL HYGIENISTS

Though dental hygiene students share many facilities with dental students, a dental hygiene program requires several areas for its own priority use.

Dental hygiene students may share classroom space, facilities of the X-ray department, and the library, for example, with dental students. If ample laboratory space is available in the dental school, this, too, may be shared, although a separate laboratory for hygiene students facilitates class scheduling for courses like dental anatomy and prophylaxis techniques, which have heavy clock-hour laboratory requirements. The laboratory should be equipped with low benches having electricity, gas, and air outlets. Sufficient

laboratory positions to accommodate an entire class are needed. A space allotment of 600 square feet per 16-student module should be adequate.

The clinic space for the dental hygiene program may be either in a section of the main clinic or in a separate clinic. There are important advantages, however, to having dental and dental hygiene students work together in the same clinic. The close association of the two groups provides opportunity for observation of each other's part in providing dental health services and can be the basis of real cooperation in patient care. The importance of this learning experience, particularly for the dental student, should be considered when planning the dental hygiene clinic space.

If clinic stations in the main clinic are assigned to the dental hygiene department, however, they should be set aside for the exclusive use of the dental hygiene students. Clinic space must be available for dental hygiene students in 3-4 hour blocks of time, on a regular, reliable, daily basis, if clock hour requirements for clinical practice are to be met within the two-year curriculum. Also, maintenance of the dental chair, unit, and cabinet is an important part of the dental hygienist's training; in order to accomplish this teaching objective, students must be assigned responsibility for a particular clinic station.

If any increase in enrollments is planned for a later date, enough space should be allocated originally and utilities installed to provide for the added students, even though all space is not immediately equipped.

Hygienists will require lounge, locker, and toilet facilities. In some schools, they will share these facilities with other women. (See chapter 21.)

The careful location of a hygiene clinic is one way of providing flexibility in school planning. If, at some later date, it should become necessary to expand the school's clinical facilities, the dental hygiene clinic can be relocated and its former facilities incorporated into other clinics, since hygiene operatories are similar in size and equipment to those used by both undergraduate and graduate dental students.

GENERAL SUPPORTING FACILITIES

20. ADMINISTRATIVE FACILITIES

21. STUDENT FACILITIES

22. GENERAL MAINTENANCE AND BUILDING SERVICES

Part

20 ADMINISTRATIVE FACILITIES

One of the focal points of dental school activity is the administrative area. Though it should be readily accessible to visitors, it need not be in a predominant location. In some schools, it is located on an upper floor, convenient to an elevator or stairway (fig. 43).

How large an administrative staff a school will need and how much space a particular administrative office will require—even what kind—are subject to innumerable variables. The administrative load of a dental school located on the main campus of the parent university may be substantially reduced because the university will handle much of the work. By contrast, the school located off campus may have an administrative operation which is all-inclusive.

Both the scope and nature of a school's administrative activities and the makeup of the staffs who direct them will vary with the school's defined objectives, with the size of its enrollment and faculty, and even with the services it provides for students.

In general most dental schools will to some extent undertake duties which fall into three broad categories—academic policy, student affairs, and business and personnel management.

ACADEMIC OFFICES

In planning the office of the dean, space must be allotted for the dean's private study and for his secretary—with due regard paid to the need for book shelves, filing space, and office supply storage. A conference room may also be necessary. In addition, offices will be required for an assistant or associate dean and his secretary. Whether or not the deans'

offices should be grouped so that the secretarial staff may share a large single office is a decision for the individual school. In programming, approximately 1,500 square feet should be adequate for these rooms. In larger schools, an office for another assistant dean may be needed.

Where the programs warrant it, graduate and postgraduate divisions will have their own officers and offices, and extensive research activity will require a research coordinator, who will also need an office. In schools with small programs, these responsibilities may be directly assigned to members of the dean's immediate staff or to a department head. Schools training dental hygienists or dental assistants will need office accommodations for the director of these programs. Some schools also include an office for part-time faculty members in the administrative area. In programming, allow 200 square feet for each office and 300 square feet for each conference room required in connection with these programs.

STUDENT AFFAIRS

Schools which do not depend upon the university for such services will require a registrar's office to process applications for admission, to supervise registrations, and to maintain student records.

Many schools also offer active programs of student assistance, including counseling and advisory services, and office space is required for the professional personnel who conduct them. In some schools, offices are provided for the chaplains appointed to serve their students. All schools will probably need space to house expanding scholarship and loan activities, and, in some, additional space will be needed to handle student housing services. There will be wide variations in the amount of space needed for these activities. In small schools or in schools with very limited responsibilities for directing student affairs, these activities will probably be combined with those of a business or personnel office.

ADMINISTRATION AREA

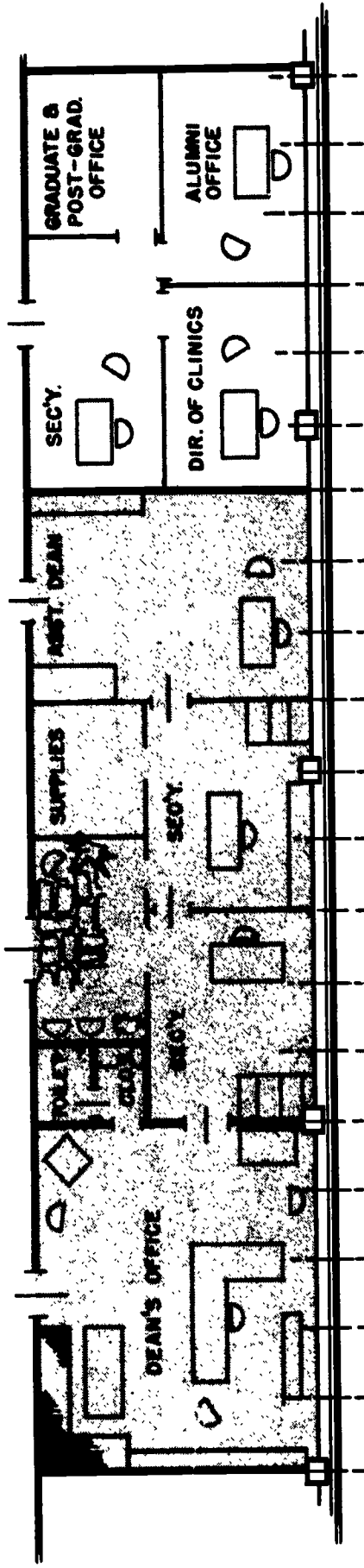
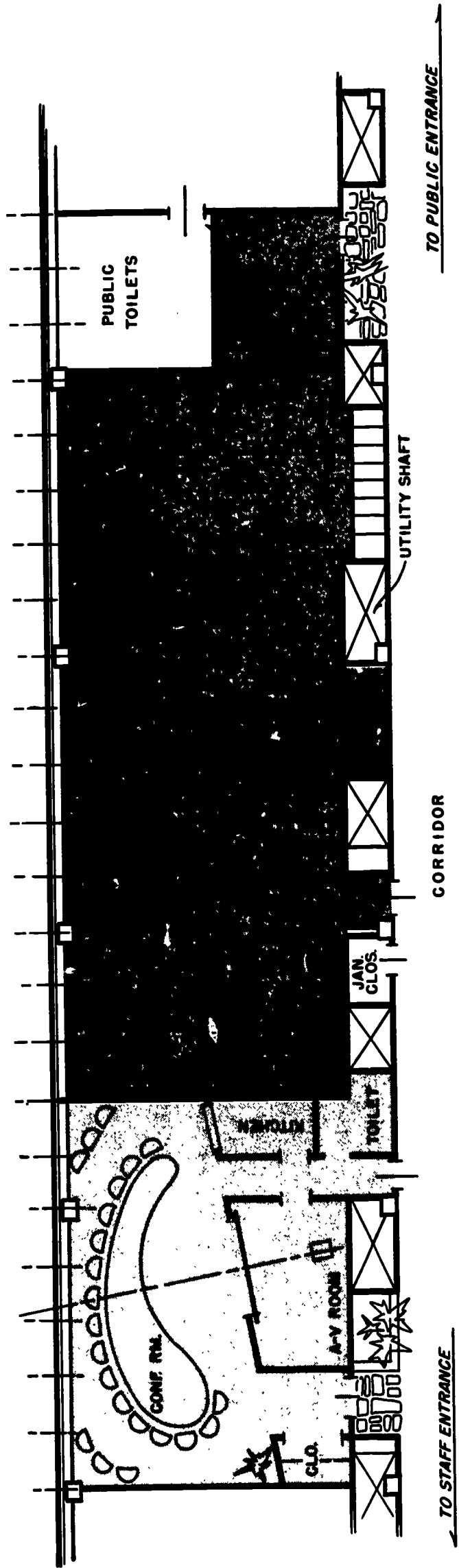

FIGURE 43.

BUSINESS AND PERSONNEL MANAGEMENT

The variety of possible administrative activities and of the facilities needed to accommodate them is nowhere greater than in business and personnel management. Some schools have little more than a cashier's office and a minimum of clerical help. Others maintain a complex accounting and fiscal operation, headed by the office of the bursar. With the growth of research and the need for a strict accounting of research grants, financial management is becoming an increasingly important function.

A public relations department, personnel offices, and stenographic-dictaphone pools may also be needed in larger institutions. Adequate space for stock rooms and administrative records is always essential. The advisability of employing an administrative director of clinics should be considered, and some schools today strengthen this service by adding a social worker who interviews prospective patients and prepares case histories to determine eligibility for cost-free clinic care.

In some activities—printing and publications is one—the type of equipment largely determines space needs. Offset printing presses will be desirable in some schools; others need little more than mimeograph machines, and their space requirements will vary accordingly.

Mail rooms, which consistently handle bulk mailing, such as announcements of continuation courses or school catalogues, require a special space allotment.

The actual allocation of space for the various business functions and for the administration of student affairs will vary widely. For the average school, however, total space needs for these two groups of functions will probably be adequately met by an allowance of 25 square feet per ECS.

However modest or ambitious the initial administrative activities of a new school may be, programming committees should make generous allowances for future expansion. The administration of a dental school is steadily becoming more complex, and as complexity of operation increases, so will the demand for more and better equipped and staffed administrative offices.

21 STUDENT FACILITIES

Like administrative offices, facilities provided for the exclusive use of students may vary in type and amount not only with the size of the school but with the availability of similar facilities elsewhere on the campus.

DINING ROOMS

Schools on university campuses or in urban centers generally do not have to consider cafeterias or dining rooms an essential—though they may prefer to operate them—because eating places will usually be available close by. Other schools may have no choice but to maintain kitchens and dining rooms for both faculty and students. Consultation with experts in restaurant management and design will provide programming committees with background information necessary for making initial estimates in the written program.

FIGURE 44. Student lounge—attractive and comfortable.



BOOK STORES

Similarly, most universities maintain large student book stores which will stock most of the texts and supplies dental students require; a dental school on campus will need to provide store space only for more specialized items, such as laboratory coats, instruments, or microscopes. Other schools may have to provide space for stores which stock everything from toilet articles to a full line of texts and special items.

For most schools, an allowance of from 8 to 10 square feet per ECS—with a minimum of 500 square feet—is a good preliminary estimate of book store space. This will provide room enough both for open displays and for some storage. If possible, the store should be located near the student lounge or the cafeteria.

STUDENT LOUNGES

The student lounge is important—perhaps indispensable—to a dental school, and the availability of similar facilities elsewhere on the campus does not, in this case, reduce the need for a lounge in the dental school itself. The lounge is the student's social center (fig. 44). He meets his friends there; it serves him as a reception room for visitors. Often, the offices of student organizations and publications are close by and so are snack bars and automatic vending machines. A room adjoining the lounge provides a pleasant setting for reading and study.

Although the number of women enrolled in undergraduate dental schools is small, schools should provide separate lounges for their convenience. In some schools, women dental students will be able to share the lounges provided for student dental hygienists and dental assistants.

Usually open only during regular school hours, student lounges should be reasonably convenient to laboratories, instruction rooms, and clinics. At the same time, the

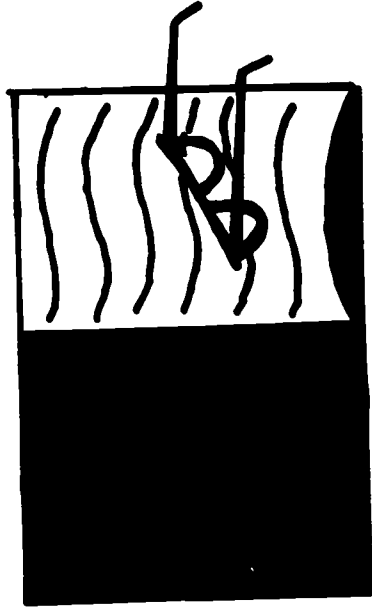
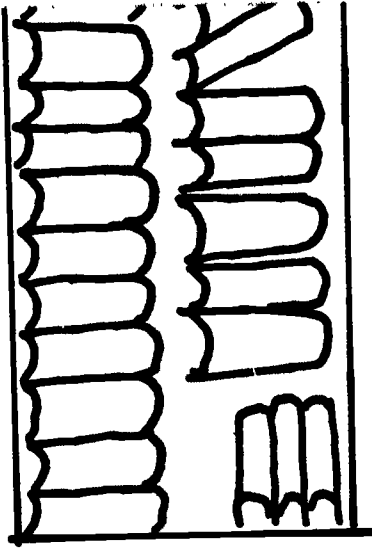
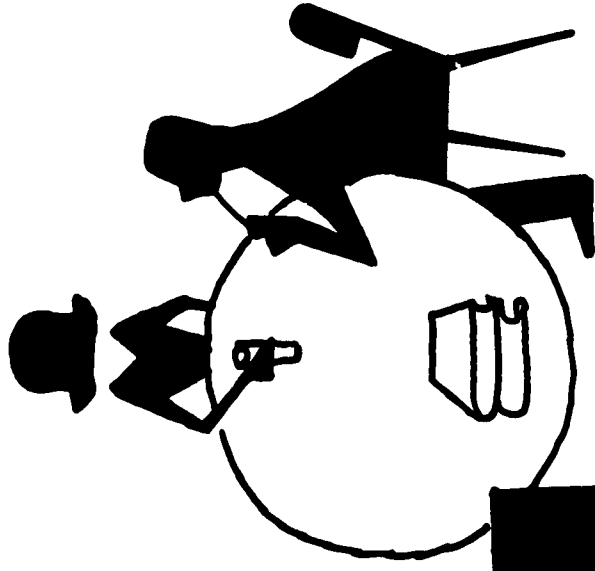

lounges should be placed so that they do not become a source of disturbances to classes in session.

In programming, the committee should estimate lounge space at 23 square feet per ECS for a class size of 96. For classes of different sizes, 200 square feet should be added or subtracted for each group of 16 students. These amounts permit simultaneous occupancy by approximately 25 percent of the total enrollment.

LOCKER ROOMS

Adjoining the lounge areas should be adequate toilet facilities and—if feasible—the student locker rooms. Locker rooms should at least be convenient to the part of the school where the student spends most of his academic day—near the basic science and preclinical technic laboratories for freshmen and sophomores, near the clinics and associated clinical laboratories for juniors and seniors.

The locker room area required for male students can be estimated at 1,800 square feet for an entering class of 48 (or three 16-student modules); this amount should be increased by 500 square feet for each additional group of 16 students. For women, the amount of locker room space will also vary according to enrollment, and space estimates should be based on the maximum enrollment anticipated. If the number of women students is small, a combination lounge and locker room may be adequate.

As to the lockers themselves, the types chosen should depend on the use to which they are put. If dental students are expected to keep their instrument cases in clothing lockers, the size of the case should be established and a prototype made so that the suitability of the lockers can be tested before they are purchased. The lockers chosen should also be large enough to accommodate other dental equipment.

22 GENERAL MAINTENANCE AND BUILDING SERVICES

The programming committee in outlining maintenance and building services must first ascertain exactly which services are to be provided by the university or health center and which are to be provided by the school itself.

If the dental school is to furnish the bulk of its own services—and its problems are often sufficiently different from those of other university components to require this—then office space must be allowed not only for the supervisory employees, such as a plant engineer and a purchasing officer, but also for a personnel department which will staff the various services.

MAINTENANCE AND REPAIR

A school which established its own maintenance and engineering services should see to it that the necessary facilities—including a carpentry shop, machine shop, mechanical shop (plumbing, heating, air conditioning, and refrigeration), and an electronics shop—are grouped in a generally convenient location.

Whether the dental school or its parent institution provides these services, substantial amounts of routine maintenance will always be required. Demands for these services can be reduced to a minimum, and the work facilitated, by giving careful attention to the placement and installation of equipment during the design and construction of the school building. All ceilings containing utility branch lines should be completely removable and vertical pipe shafts should be fully accessible.

Because the biggest problems will undoubtedly be in the maintenance and repair of mechanical equipment, enough space should be allotted for major items, such as air conditioning, boilers, pumps, and telephone installations, to simplify their service and repair. These are highly technical matters; exact details must be worked out by specialists, and the plant engineer, maintenance chief, or engineering department supervisor should be present during the installation of equipment.

BUILDING SERVICES

Space must be assigned for employee locker rooms, janitorial floor closets and supply storage, general building supply storage, laundry collection room, and incinerator room.

A dental school which depends on the university or the community for dining room or cafeteria service, supplementing these with small snack bars or automatic canteens, will not require extensive facilities for the storage or preparation of food or the disposal of garbage. On the other hand, the school with its own eating places must not only have kitchens but locate and plan them in such a way that storage and disposal can be efficiently handled.

A dental school on a campus which has ample central storage and incinerator facilities may need no more than the usual departmental storage areas, plus rooms where rubbish and garbage can be left pending removal to the central incinerator. Otherwise, central storage facilities will be needed at the dental school and an incinerator should be in a room large enough for temporary rubbish storage.

CONCLUSION

23. PLANNING FOR THE FUTURE

Part

23 PLANNING FOR THE FUTURE

Future is a key word in any meaningful discussion of dental school planning. Some of the facilities occupied by today's schools were built in the 19th century. Schools yet to be built must therefore be planned for service extending well into the 21st century.

No one familiar with the changes beginning to occur in dental practice and in dental education would suggest that programming committees will find it easy either to foresee or to resolve all the problems the future poses. But this is the job they must attempt, for most educators are convinced that, in the long run, no course of action would be more hazardous than that of limiting new schools to the demands of current programs and methods.

The responsibility of planning groups is therefore great. It is hoped that the discussion of basic issues presented in this publication will be of practical assistance to them in meeting it. Additional aids will be found in the appendixes which follow.

THE APPENDIXES

Appendix I is a sample of a form which can be used in studying and outlining each element of the dental school. It covers such questions as the nature, dimensions, and special requirements of the needed space, its proposed use and preferred location, and the services, utilities, and equipment required. The form can, of course, be shortened, expanded or revised as conditions demand.

Appendix II presents a detailed schedule of space allowances for five schools with entering classes ranging in size

from 48 to 112 students. Though the estimates are for hypothetical schools, the schedule itself has been carefully constructed and it can be used as a general guide in estimating the space requirements of actual schools.

In using the schedule, the planning committee will recognize that certain assumptions of programming have been made. Many are self-evident; others deserve emphasis. The same assumptions apply for each hypothetical school.

Each school has full administrative control over its activities. It has its own library, but not its own auditorium. The basic sciences are taught in the dental school, and space allotments have been made for one departmental laboratory in anatomy and two multidiscipline laboratories—one a high-bench and the other a low-bench laboratory.

Both the freshman and sophomore classes have a separate whole-class preclinical laboratory. Two whole-class clinical laboratories are also provided, one each for the junior and senior years.

The school conducts modest programs of research and graduate study, and the space allotted for them is enough to provide the faculties and students with separate facilities adjacent to the areas in which they teach and study. The assumed number of full-time faculty and of graduate and postgraduate students is shown for each clinical and basic science department.

Although training for dental hygienists will not be offered immediately, the school has been programmed so that it may expand to accommodate these activities later; space estimates are given in a separate table.

Because the school will be fully equipped for ETV, space is allowed for a central ETV studio.

No deduction has been made for attrition in the upper classes, and most figures have been rounded to the higher full hundred as a means of allowing for "plan loss"—the difference between a tabular figure and the actual net room area in the completed school.

The tables in appendix II also include space allocations for five schools for which the same assumptions hold, except that these schools will teach only the clinically oriented basic sciences. Allowance has been made for one low bench laboratory and for the ancillary and supporting facilities required for teaching oral histology, oral pathology, oral medicine.

To convert its own space requirements into cost estimates, the committee may follow the procedure outlined in chapter 5. For example, the estimated net space required

for the school of 96 entering students programmed to furnish all of its basic science instruction totals 187,000 square feet (table A-2). Since the net area occupies only 65 percent of the total plant, however, the gross area required is 287,000 square feet (table A-1). Using the average cost of \$30 per square foot, as in chapter 5, the school would cost approximately \$8.6 million, if built today. If another year will pass before contracts can be let, then \$8.9 million is a safer estimate, since it includes an allowance for inflation.

APPENDIXES

- I. SPACE DESCRIPTION FORM
- II. SPACE ALLOCATION TABLES
- III. LIST OF FLOOR PLANS AND PHOTOGRAPHS
- IV. REFERENCES
- V. SELECTED BIBLIOGRAPHY

Part

I SPACE DESCRIPTION FORM

PROJECT SPACE NO.
 DEPT.
 DIVISION
 PHASE OR STEP NUMBER
 A. TYPE OF SPACE
 1. DIMENSIONS (minimum in feet) ASSIGNABLE SQ. FT.
 2. TOTAL NUMBER OF ASSIGNED OCCUPANTS
 3. TOTAL NUMBER OCCUPANTS AT ANY ONE TIME UTILIZATION HRS. /WK.
 B. PROPOSED USE OF SPACE

C. LOCATION PREFERENCE (FLOOR) AND RELATIONSHIP TO OTHER SPACES (IF ANY):

D. SPECIAL SPACE REQUIREMENTS
 1. AUDIOVISUAL QUANTITY
 2. CHALKBOARDS—LENGTH
 3. VIBRATION AND/OR NOISE PRODUCING EQUIPMENT (Describe)
 4. TEMPERATURE AND/OR HUMIDITY CONTROL
 5. EXTRA ACOUSTICAL REQUIREMENTS (Describe) DESCRIBE
 6. FIRE AND/OR HEALTH HAZARDS—YES NO
 7. OTHER (Intercom, TV outlets, etc.)

E. SERVICES AND UTILITIES
 1. SPECIAL ELECTRICAL OUTLETS: YES NO DESCRIBE
 2. GAS: YES NO 3. AIR: YES NO 4. VACUUM: YES NO
 5. ASPIRATORS: YES NO 6. SINKS: YES NO QUANTITY
 7. FUME HOODS: YES NO 8. WATER: YES NO
 9. OTHER:

F. FURNITURE AND EQUIPMENT (occupying floor space)

QUANTITY	DESCRIPTION	QUANTITY	DESCRIPTION

Prepared by: Date:



II SPACE ALLOCATION TABLES

	PAGE
SUMMARY TABLES	90
A-1 Average Construction Costs for 10 Hypothetical Schools	
A-2 Summary Space Allocations for 10 Hypothetical Schools	
BASIC SCIENCE FACILITIES	92
B-1 Low-Bench Disciplines (Microbiology, Pathology (Oral and General), and Histology)	
B-2 High-Bench Disciplines (Biochemistry, Physiology and Pharmacology)	
B-3 Anatomy	
CLINICAL AND PRECLINICAL FACILITIES	95
C-1 Preclinical Laboratories	
C-2 Clinical Laboratories	
C-3 Operative Dentistry	
C-4 Oral Diagnosis	
C-5 Radiology	
C-6 Oral Surgery	
C-7 Orthodontics	
C-8 Pedodontics	
C-9 Periodontics, Endodontics, and Oral Medicine	
C-10 Prosthetics	
C-11 Crown and Bridge	
C-12 Chronically Ill and Handicapped	
COMMON FACILITIES	101
D-1 Lecture Rooms	
D-2 Library	
D-3 ETV and Visual Aids Departments	
D-4 Animal Quarters	
D-5 Technical Shops	
GENERAL SUPPORTING FACILITIES	106
E-1 Administration	
E-2 Special Facilities for Students and Faculty	
E-3 General Maintenance and Building Services	
DENTAL AUXILIARY PROGRAMS	109
F-1 Dental Hygienist (2-year) Program	
F-2 Dental Assistant (1-year) Program	

A. SUMMARY TABLES

Table A-1

AVERAGE CONSTRUCTION COSTS FOR 10 HYPOTHETICAL SCHOOLS WITH AND WITHOUT FACILITIES FOR AUXILIARY PERSONNEL PROGRAMS

TYPE OF AREA	SIZE OF ENTERING DENTAL CLASS*					
	In schools with facilities for ALL BASIC SCIENCES			In schools with facilities for CLINICALLY-ORIENTED BASIC SCIENCES ONLY		
	112	96	80	64	48	
Estimated cost in millions of dollars (@ \$30 per square foot**)	\$9.9	\$8.6	\$7.6	\$6.5	\$5.6	\$4.1
Gross square feet	331,608	287,500	254,162	217,131	187,962	137,708
Net square feet	215,545	186,875	165,205	141,135	122,175	89,510
Basic science facilities	60,600	53,750	47,200	39,350	35,500	6,650
Clinical (and preclinical) facilities	88,375	73,585	67,425	59,665	51,205	51,205
Common facilities	31,570	28,440	23,780	19,820	16,670	14,555
General supporting facilities	35,000	30,900	26,800	22,300	18,800	17,100
Estimated cost in millions of dollars (@ \$30 per square foot**)	\$10.8	\$9.5	\$8.5	\$7.2	\$6.3	\$4.8
Gross square feet	360,531	316,423	283,085	239,900	210,731	160,477
Net square feet	234,345	205,675	184,005	155,935	136,975	104,310
Basic footage	215,545	186,875	165,205	141,135	122,175	89,510
Dental hygienist facilities:						
64 ECS	12,800	12,800	12,800	9,900	9,900	9,900
48 ECS						
Dental assistant facilities:						
64 ECS	6,000	6,000	6,000	4,900	4,900	4,900
48 ECS						

* Assumed numbers of faculty and of graduate and postgraduate students are shown in detailed tables which follow. Other program assumptions are described in chapter 23.
 ** This cost covers construction only. It does not include cost of site or site improvements, equipment or architectural or other fees. It is an average figure and should be carefully checked against local experience before applying to a specific building project. Actual costs for recently constructed schools have ranged as much as 50 percent above or below this \$30 average (see chapter 5).



Table A-2

SUMMARY SPACE ALLOCATIONS—10 HYPOTHETICAL SCHOOLS

TYPE OF AREA	SIZE OF ENTERING CLASS					In schools with facilities for				
						CLINICALLY-ORIENTED BASIC SCIENCES ONLY				
	112	96	80	64	48	112	96	80	64	48
Net square feet—all areas.....	215,545	186,875	165,205	141,135	122,175	156,220	134,400	120,230	104,700	89,510
BASIC SCIENCE FACILITIES										
Teaching laboratory and ancillary facilities.....	60,600	53,750	47,200	39,350	35,500	11,250	9,900	8,750	7,650	6,650
Special laboratory facilities.....	22,600	19,950	17,300	14,550	12,200	5,900	5,100	4,400	3,700	3,000
Faculty offices and research laboratories.....	1,900	1,900	1,900	1,900	1,900	700	700	700	700	700
Graduate study and research areas.....	17,100	14,400	12,300	9,000	8,100	2,100	1,800	1,500	1,200	900
Other departmental facilities.....	6,100	5,400	4,600	3,400	2,600	750	600	450	450	450
	12,900	12,300	11,100	10,500	10,500	1,800	1,700	1,700	1,600	1,600
CLINICAL (AND PRECLINICAL) FACILITIES										
Operatories and ancillary facilities.....	98,375	73,585	67,425	59,665	51,205	88,375	73,585	67,425	59,665	51,205
Laboratories and ancillary facilities.....	53,475	44,385	40,325	36,865	32,305	53,475	44,385	41,325	36,865	32,305
Faculty offices and research areas.....	18,800	16,400	14,000	11,400	8,800	18,800	16,400	14,000	11,400	8,800
Graduate study and research areas.....	13,200	10,600	10,600	9,400	8,200	13,200	10,600	10,000	9,400	8,200
	2,900	2,200	2,100	2,060	1,900	2,900	2,200	2,100	2,000	1,900
COMMON FACILITIES										
Lecture rooms.....	31,570	28,440	23,780	19,820	16,670	24,395	22,615	19,455	16,985	14,555
Library.....	7,100	6,200	4,900	4,000	3,100	5,300	4,600	3,700	3,000	2,300
ETV and visual aids.....	10,780	9,950	9,120	8,290	7,560	10,780	9,950	9,120	8,290	7,560
ETV.....	4,790	4,590	3,660	2,830	2,510	4,190	4,090	3,260	2,520	2,320
Visual aids.....	2,650	2,550	2,200	1,650	1,500	2,550	2,550	2,200	1,650	1,500
Special supporting facilities for laboratories and clinics.....	2,140	2,040	1,460	1,160	1,010	1,640	1,540	1,060	870	820
Animal quarters.....	8,900	7,700	6,100	4,700	3,500	4,125	3,975	3,375	3,175	2,375
Technical shops.....	6,900	5,700	4,700	3,500	2,500	2,525	2,375	2,275	2,175	1,575
	2,000	2,000	1,400	1,200	1,000	1,600	1,600	1,100	1,000	800
GENERAL SUPPORTING FACILITIES										
Administration.....	35,000	30,900	26,800	22,300	18,800	32,200	28,300	24,600	20,400	17,100
Special facilities for students and faculty.....	5,700	5,300	4,900	4,300	3,800	5,500	5,100	4,700	4,100	3,600
General maintenance and building services.....	13,600	12,100	10,300	8,700	7,300	12,000	10,700	9,100	7,700	6,500
	15,700	13,500	11,600	9,300	7,700	14,700	12,500	10,800	8,600	7,000

B. BASIC SCIENCE FACILITIES

Table B-1
SPACE ALLOCATIONS FOR BASIC SCIENCE FACILITIES
LOW-BENCH DISCIPLINES (MICROBIOLOGY, PATHOLOGY (ORAL AND GENERAL), AND HISTOLOGY)

TYPE OF AREA	SIZE OF ENTERING DENTAL CLASS						In schools with facilities for CLINICALLY ORIENTED BASIC SCIENCES ONLY								
	In schools with facilities for ALL BASIC SCIENCES			In schools with facilities for BASIC SCIENCES ONLY			In schools with facilities for BASIC SCIENCES ONLY			In schools with facilities for BASIC SCIENCES ONLY					
	112	96	80	64	48	112	96	80	64	48	112	96	80	64	48
Faculty.....	(25)	(21)	(18)	(13)	(12)	(7)	(6)	(5)	(4)	(3)	(7)	(6)	(5)	(4)	(3)
Graduate and postgraduate students.....	(19)	(16)	(14)	(10)	(8)	(5)	(4)	(3)	(3)	(3)	(5)	(4)	(3)	(3)	(3)
Net square feet—all areas.....	24,250	21,300	18,200	14,600	13,200	11,250	9,900	8,750	7,650	6,650	11,250	9,900	8,750	7,650	6,650
TEACHING LABORATORY	4,200	3,600	3,000	2,400	1,800	4,200	3,600	3,000	2,400	1,800	4,200	3,600	3,000	2,400	1,800
ANCILLARY TEACHING FACILITIES	3,600	3,000	2,500	1,900	1,700	1,700	1,500	1,400	1,300	1,200	1,700	1,500	1,400	1,300	1,200
Microscope storage.....	600	500	400	300	200	600	500	400	300	200	600	500	400	300	200
Tissue preparation room.....	900	800	700	600	600	900	800	700	600	600	900	800	700	600	600
Glass washing and sterilization.....	700	600	500	400	300	700	600	500	400	300	700	600	500	400	300
Glass storage.....	400	300	200	100	100	400	300	200	100	100	400	300	200	100	100
Media preparation.....	500	400	300	200	200	500	400	300	200	200	500	400	300	200	200
Slides and records.....	300	200	200	100	100	300	200	200	100	100	300	200	200	100	100
Animal room.....	200	200	200	200	200	200	200	200	200	200	200	200	200	200	200
SPECIAL LABORATORY FACILITIES	700	700	700	700	700	700	700	700	700	700	700	700	700	700	700
Cold room.....	100	100	100	100	100	100	100	100	100	100	100	100	100	100	100
Electron microscope.....	600	600	600	600	600	600	600	600	600	600	600	600	600	600	600
DEPARTMENTAL FACILITIES	15,750	14,000	12,000	9,600	9,000	4,650	4,100	3,650	3,250	2,950	4,650	4,100	3,650	3,250	2,950
Faculty facilities.....	7,500	6,300	5,400	3,900	3,600	2,100	1,900	1,500	1,200	900	2,100	1,900	1,500	1,200	900
Offices.....	5,000	4,200	3,600	2,600	2,400	1,400	1,200	1,000	800	600	1,400	1,200	1,000	800	600
Laboratories.....	2,500	2,100	1,800	1,300	1,200	700	600	500	400	300	700	600	500	400	300
Graduate facilities.....	2,850	2,600	2,100	1,500	1,200	750	600	450	450	450	750	600	450	450	450
Offices.....	950	800	700	500	400	250	200	150	150	150	250	200	150	150	150
Laboratories.....	1,900	1,800	1,400	1,000	800	500	400	300	300	300	500	400	300	300	300
General facilities.....	5,400	5,100	4,500	4,200	4,200	1,800	1,700	1,700	1,600	1,600	1,800	1,700	1,700	1,600	1,600
Departmental research laboratories.....	1,800	1,800	1,200	1,200	1,200	500	600	600	600	600	500	600	600	600	600
Data rooms.....	600	600	600	600	600	200	200	200	200	200	200	200	200	200	200
Seminar rooms.....	1,200	900	900	600	600	400	300	300	300	200	400	300	300	200	200
Departmental secretary.....	300	300	300	300	300	100	100	100	100	100	100	100	100	100	100
Departmental storage.....	600	600	600	600	600	200	200	200	200	200	200	200	200	200	200
Conference rooms.....	900	900	900	900	900	300	300	300	300	300	300	300	300	300	300

Table B-2

SPACE ALLOCATIONS FOR BASIC SCIENCE FACILITIES
HIGH-BENCH DISCIPLINES (BIOCHEMISTRY, PHYSIOLOGY AND PHARMACOLOGY)

TYPE OF AREA	SIZE OF ENTERING DENTAL CLASS					
	In schools with facilities for ALL BASIC SCIENCES			In schools with facilities for CLINICALLY-ORIENTED BASIC SCIENCES ONLY		
	112	96	80	64	48	
Faculty	(25) (19)	(21) (16)	(18) (14)	(13) (10)	(12) (8)	
Graduate and postgraduate students						
Net square feet—all areas	26,750	23,900	21,100	17,700	16,100	
TEACHING LABORATORY	4,200	3,600	3,000	2,400	1,800	
ANCILLARY TEACHING FACILITIES	4,900	4,600	4,200	3,800	3,400	
Preparation room	1,200	1,200	1,200	1,200	1,200	
Storage and supply area	2,400	2,100	1,800	1,500	1,200	
Special equipment room	500	500	400	300	200	
Animal rooms	400	400	400	400	400	
Cold room	400	400	400	400	400	
SPECIAL LABORATORY FACILITIES	1,200	1,200	1,200	1,200	1,200	
Constant temperature room	200	200	200	200	200	
Radio-isotope laboratory	400	400	400	400	400	
Ultracentrifuge	200	200	200	200	200	
Chromatography	400	400	400	400	400	
DEPARTMENTAL FACILITIES	16,450	14,500	12,700	10,300	9,700	
Faculty facilities	7,500	6,300	5,400	3,900	3,600	
Offices	5,000	4,200	3,600	2,600	2,400	
Laboratories	2,500	2,100	1,800	1,300	1,200	
Graduate facilities	2,850	2,400	2,100	1,500	1,200	
Offices	950	800	700	500	400	
Laboratories	1,900	1,600	1,400	1,000	800	
General facilities	5,400	5,100	4,500	4,200	4,200	
Departmental research laboratories	1,800	1,800	1,200	1,200	1,200	
Seminar rooms	1,200	900	900	600	600	
Data rooms	600	600	600	600	600	
Conference rooms	900	900	900	900	900	
Departmental secretarial offices	300	300	300	300	300	
Departmental storage	600	600	600	600	600	
Maintenance	700	700	700	700	700	
Electronics shop	300	300	300	300	300	
Woodworking and metal shop	400	400	400	400	400	
						NONE
						NONE

C. CLINICAL AND PRECLINICAL FACILITIES

Table C-1
SPACE ALLOCATIONS FOR CLINICAL and preclinical FACILITIES
PRECLINICAL LABORATORIES

TYPE OF AREA	SIZE OF ENTERING CLASS In schools with or without facilities for all basic sciences					
	112	96	80	64	48	(3)
Faculty.....	10,000	8,800	7,600	6,300	4,800	4,800
Net square feet—all areas.....	8,400	7,200	6,000	4,800	3,600	3,600
TEACHING FACILITIES.....	4,200	3,600	3,000	2,400	1,800	1,800
Freshman laboratory.....	4,200	3,600	3,000	2,400	1,800	1,800
Sophomore laboratory.....	1,000	1,000	1,000	900	800	800
ANCILLARY TEACHING FACILITIES.....	600	600	600	600	600	600
Processing laboratory.....	400	400	400	300	200	200
Storage area.....	600	600	600	600	400	400
FACULTY FACILITIES.....	400	400	400	400	200	200
Offices.....	200	200	200	200	200	200
Research laboratories.....						

Table C-2
SPACE ALLOCATIONS FOR CLINICAL and preclinical FACILITIES
CLINICAL LABORATORIES

TYPE OF AREA	SIZE OF ENTERING CLASS In schools with or without facilities for all basic sciences					
	112	96	80	64	48	(3)
Faculty.....	10,000	8,800	7,600	6,300	4,800	4,800
Net square feet—all areas.....	8,400	7,200	6,000	4,800	3,600	3,600
TEACHING FACILITIES.....	4,200	3,600	3,000	2,400	1,800	1,800
Junior laboratory.....	4,200	3,600	3,000	2,400	1,800	1,800
Senior laboratory.....	1,000	1,000	1,000	900	800	800
ANCILLARY TEACHING FACILITIES.....	600	600	600	600	600	600
Processing laboratory.....	400	400	400	300	200	200
Storage area.....	600	600	600	600	400	400
FACULTY FACILITIES.....	400	400	400	400	200	200
Offices.....	200	200	200	200	200	200
Research laboratory.....						

Table C-3
SPACE ALLOCATIONS FOR CLINICAL and preclinical FACILITIES
OPERATIVE DENTISTRY

TYPE OF AREA	SIZE OF ENTERING CLASS In schools with or without facilities for all basic sciences				
	112	96	80	64	48
Faculty.....	(14)	(12)	(10)	(8)	(6)
Graduates and postgraduates.....	(18)	(16)	(14)	(12)	(10)
Undergraduate bloc.....	(112)	(96)	(80)	(64)	(48)
Net square feet—all areas.....	25,700	22,040	18,680	15,120	12,060
Operatories.....	13,000	11,200	9,400	7,600	5,800
Demonstration.....	800	600	600	400	400
Waiting rooms.....	2,600	2,240	1,880	1,520	1,160
Clinic reception, secretary, records, and storage.....	2,100	1,500	1,500	1,200	1,000
Sterilization and sterile supply.....	500	500	500	400	400
Supply and dispensing.....	700	600	500	400	400
Treatment planning and consultation.....	900	600	600	600	600
Faculty offices.....	2,800	2,400	2,000	1,600	1,200
Faculty research.....	1,400	1,200	1,000	800	600
Graduate study and laboratory areas.....	900	800	700	600	500

Table C-4
SPACE ALLOCATIONS FOR CLINICAL and preclinical FACILITIES
ORAL DIAGNOSIS

TYPE OF AREA	SIZE OF ENTERING CLASS In schools with or without facilities for all basic sciences				
	112	96	80	64	48
Faculty.....	(2)	(1)	(1)	(1)	(1)
Graduates and postgraduates.....	(12)	(8)	(8)	(8)	(4)
Undergraduate bloc.....	4,020	2,680	2,680	2,680	1,940
Net square feet—all areas.....	1,020	680	680	680	340
Operatories.....	900	600	600	600	300
Demonstration operatories.....	300	300	300	300	300
Waiting rooms*.....	600	300	300	300	300
Clinic reception, secretary, records, and storage.....	400	200	200	200	200
Treatment planning and consultation.....	200	200	200	200	200
Faculty offices.....	600	400	400	400	300
Faculty research.....	200	200	200	200	200
Graduate study and laboratory areas.....	600	400	400	400	300
Clinical diagnosis laboratory.....					

* Shared with the radiology clinic.

Table C-5
SPACE ALLOCATIONS FOR CLINICAL and preclinical FACILITIES
RADIOLOGY

TYPE OF AREA	SIZE OF ENTERING CLASS In schools with or without facilities for all basic sciences				
	112	96	80	64	48
Faculty.....	(2)	(2)	(2)	(2)	(1)
Graduates and postgraduates.....	(2)	(2)	(2)	(2)	(2)
Undergraduate bloc.....	(12)	(8)	(8)	(8)	(4)
Net square feet—all areas.....	4,570	3,810	3,810	3,810	2,950
Operatories.....	1,810	1,150	1,150	1,150	690
Extra-oral X-ray room.....	260	260	260	260	260
Waiting rooms*.....	300	300	300	300	300
Clinic reception, secretary, records, and storage.....	600	300	300	300	300
Treatment planning and consultation.....	600	600	600	600	400
Faculty and staff offices.....	200	200	200	200	200
Faculty research.....	200	200	200	200	200
Graduate study and laboratory areas.....	500	500	500	500	300
Darkroom, viewing and mounting.....	300	300	300	300	300
Film library.....					

*Shared with the diagnostic clinic

Table C-6
SPACE ALLOCATIONS FOR CLINICAL and preclinical FACILITIES
ORAL SURGERY

TYPE OF AREA	SIZE OF ENTERING CLASS In schools with or without facilities for all basic sciences				
	112	96	80	64	48
Faculty.....	(3)	(2)	(2)	(2)	(2)
Graduates and postgraduates.....	(6)	(4)	(4)	(4)	(4)
Undergraduate bloc.....	(8)	(4)	(4)	(4)	(4)
Net square feet—all areas.....	5,875	3,845	3,845	3,845	3,845
Operatories.....	1,400	800	800	800	800
Demonstration and general anesthesia operatories.....	400	200	200	200	200
Waiting rooms.....	780	480	480	480	480
Clinic reception, secretary, records, and storage.....	150	150	150	150	150
Sterilization and sterile supply.....	400	300	300	300	300
Supply and dispensing.....	300	150	150	150	150
Medicine storage.....	120	80	80	80	80
Treatment planning and consultation.....	300	300	300	300	300
Faculty offices.....	600	400	400	400	400
Faculty research.....	300	200	200	200	200
Graduate study and laboratory areas.....	300	200	200	200	200
Recovery area.....	500	300	300	300	300
TV control and observation gallery.....	100	75	75	75	75
Scrub up area.....	75	60	60	60	60
Toilet areas.....	150	150	150	150	150

Table C-7
SPACE ALLOCATIONS FOR CLINICAL and preclinical FACILITIES
ORTHODONTICS

TYPE OF AREA	SIZE OF ENTERING CLASS In schools with or without facilities for all basic sciences				
	112	96	80	64	48
Faculty.....	(3)	(2)	(2)	(2)	(2)
Graduates and postgraduates.....	(6)	(4)	(4)	(4)	(4)
Undergraduate bloc.....	(16)	(16)	(16)	(12)	(8)
Net square feet—all areas.....	4,500	3,700	3,700	3,300	2,900
Operatories.....	2,200	2,000	2,000	1,600	1,200
Demonstration operatories.....	400	200	200	200	200
Waiting rooms*.....	150	150	150	150	150
Clinic reception, secretary, records, and storage.....	150	150	150	150	150
Sterilization and sterile supply.....	150	150	150	150	150
Supply and dispensing.....	300	300	300	300	300
Medicine Storage.....	600	400	400	400	400
Treatment planning and consultation.....	300	200	200	200	200
Faculty offices.....	300	200	200	200	200
Faculty research.....	300	200	200	200	200
Graduate study and laboratory areas.....	100	100	100	100	100
Measurements.....					

* Shared with the pedodontic clinic.

Table C-8
SPACE ALLOCATIONS FOR CLINICAL and preclinical FACILITIES
PEDODONTICS

TYPE OF AREA	SIZE OF ENTERING CLASS In schools with or without facilities for all basic sciences				
	112	96	80	64	48
Faculty.....	(3)	(2)	(2)	(2)	(2)
Graduates and postgraduates.....	(6)	(4)	(4)	(4)	(4)
Undergraduate bloc.....	(16)	(16)	(16)	(12)	(8)
Net square feet—all areas.....	5,000	4,100	4,100	3,700	3,300
Operatories.....	2,200	2,000	2,000	1,600	1,200
Demonstration operatories.....	400	200	200	200	200
Waiting rooms*.....	600	500	500	500	500
Clinic reception, secretary, records, and storage.....	156	150	150	150	150
Sterilization and sterile supply.....	150	150	150	150	150
Supply and dispensing.....	150	150	150	150	150
Medicine storage.....	300	300	300	300	300
Treatment planning and consultation.....	600	400	400	400	400
Faculty offices.....	300	200	200	200	200
Faculty research.....	300	200	200	200	200
Graduate study and laboratory areas.....	300	200	200	200	200

* Shared with the orthodontics clinic.

Table C-9
SPACE ALLOCATIONS FOR CLINICAL and preclinical FACILITIES
PERIODONTICS, ENDODONTICS, AND ORAL MEDICINE

TYPE OF AREA	SIZE OF ENTERING CLASS In schools with or without facilities for all basic sciences				
	112	96	80	64	48
Faculty.....	(3)	(2)	(2)	(2)	(2)
Graduates and postgraduates.....	(6)	(4)	(4)	(4)	(4)
Undergraduate bloc.....	(16)	(16)	(16)	(16)	(16)
Net square feet—all areas.....	4,830	4,030	4,030	4,030	4,030
Operatories.....	2,200	2,000	2,000	2,000	2,000
Demonstration operatories.....	400	200	200	200	200
Waiting rooms.....	400	400	400	400	400
Clinic reception, secretary, records, and storage.....	100	100	100	100	100
Sterilization and sterile supply.....	150	150	150	150	150
Supply and dispensing.....	80	80	80	80	80
Medicine storage.....	300	300	300	300	300
Treatment planning and consultation.....	600	400	400	400	400
Faculty offices.....	300	200	200	200	200
Faculty research.....	300	200	200	200	200
Graduate study and laboratory areas.....					

Table C-10
SPACE ALLOCATION FOR CLINICAL and preclinical FACILITIES
PROSTHETICS

TYPE OF AREA	SIZE OF ENTERING CLASS In schools with or without facilities for all basic sciences				
	112	96	80	64	48
Faculty.....	(4)	(3)	(3)	(3)	(3)
Graduates and postgraduates.....	(6)	(4)	(4)	(4)	(4)
Undergraduate bloc.....	(24)	(20)	(20)	(16)	(16)
Net square feet—all areas.....	6,300	4,800	4,800	4,400	4,400
Operatories.....	3,000	2,400	2,400	2,000	2,000
Demonstration operatories.....	400	200	200	200	200
Waiting rooms*.....	500	500	500	500	500
Clinic reception, secretary, records, and storage.....	150	150	150	150	150
Sterilization and sterile supply.....	150	150	150	150	150
Supply and dispensing.....					
Medicine storage.....	600	300	300	300	300
Treatment planning and consultation.....	800	600	600	600	600
Faculty offices.....	400	300	300	300	300
Faculty research.....	300	200	200	200	200
Graduate study and laboratory areas.....					

*Shared with the crown and bridge clinic.

Table C-11
SPACE ALLOCATIONS FOR CLINICAL and preclinical FACILITIES
CROWN AND BRIDGE

TYPE OF AREA	SIZE OF ENTERING CLASS In schools with or without facilities for all basic sciences				
	112	96	80	64	48
Faculty.....	(4)	(3)	(3)	(3)	(3)
Graduates and postgraduates.....	(6)	(4)	(4)	(4)	(4)
Undergraduate bloc.....	(24)	(24)	(20)	(16)	(16)
Net square feet—all areas.....	5,500	4,900	4,500	4,100	4,100
Operatories.....	3,000	2,800	2,400	2,000	2,000
Demonstration operatories.....	200	200	200	200	200
Waiting rooms *.....	150	150	150	150	150
Clinic reception, secretary, records, and storage.....	150	150	150	150	150
Sterilization and sterile supply.....	150	150	150	150	150
Supply and dispensing.....	300	300	300	300	300
Medicine storage.....	800	600	600	600	600
Treatment planning and consultation.....	400	300	300	300	300
Faculty offices.....	300	200	200	200	200
Graduate study and laboratory areas.....	200	200	200	200	200
Ceramics laboratory.....	200	200	200	200	200

*Shared with the prosthetic clinic.

Table C-12
SPACE ALLOCATIONS FOR CLINICAL and preclinical FACILITIES
CHRONICALLY ILL AND HANDICAPPED

TYPE OF AREA	SIZE OF ENTERING CLASS In schools with or without facilities for all basic sciences				
	112	96	80	64	48
Faculty.....	(1)	(1)	(1)	(1)	(1)
Graduates and postgraduates.....	(4)	(4)	(4)	(4)	(4)
Undergraduate bloc.....	2,000	2,000	2,000	2,000	2,000
Net square feet—all areas.....	500	500	500	500	500
Operatories.....	200	200	200	200	200
Demonstration operatories.....	200	200	200	200	200
Waiting rooms.....	100	100	100	100	100
Clinic reception, secretary, records, and storage.....	100	100	100	100	100
Sterilization and sterile supply.....	100	100	100	100	100
Supply and dispensing.....	100	100	100	100	100
Medicine storage.....	300	300	300	300	300
Treatment planning and consultation.....	200	200	200	200	200
Faculty offices.....	200	200	200	200	200
Graduate study and laboratory areas.....	100	100	100	100	100
Recovery area.....	180	180	180	180	180
Toilet areas.....	180	180	180	180	180

D. COMMON FACILITIES

Table D-1
SPACE ALLOCATIONS FOR COMMON FACILITIES
LECTURE ROOMS

TYPE OF AREA	SIZE OF ENTERING DENTAL CLASS											
	In schools with facilities for ALL BASIC SCIENCES						In schools with facilities for CLINICALLY-ORIENTED BASIC SCIENCES ONLY					
	112	96	80	64	48	112	96	80	64	48		
Net square feet—all areas.....	7,100	6,200	4,900	4,000	3,100	5,300	4,600	3,700	3,000	2,300		
Lecture room No. 1.....	1,800	1,600	1,200	1,000	800	1,800	1,600	1,200	1,000	800		
Lecture room No. 2.....	1,800	1,600	1,200	1,000	800	3,500	3,000	2,500	2,000	1,500		
Lecture room No. 3.....	3,500	3,000	2,500	2,000	1,500							

Table D-2
SPACE ALLOCATIONS FOR COMMON FACILITIES
LIBRARY (25,000 Volumes—300 Serials)

TYPE OF AREA	SIZE OF ENTERING CLASS In schools with or without facilities for all basic sciences				
	112	96	80	64	48
Net square feet—all areas.....	10,780	9,950	9,120	8,290	7,560
PUBLIC SPACES	6,970	6,140	5,310	4,480	3,750
Entry and display.....	600	600	600	600	600
General reading and reference.....	3,800	3,300	2,800	2,300	1,800
Tape recording rooms.....	200	200	200	200	200
Microfilm reading.....	400	300	200	100	100
Periodical room.....	540	480	420	360	300
Historical collection.....	300	300	300	300	300
Joint study and conference.....	600	500	400	300	200
Carrels.....	530	460	390	320	250
STAFF OFFICES	480	480	480	480	480
Chief librarian.....	180	180	180	180	180
Assistant librarian.....	180	180	180	180	180
Secretary's office.....	120	120	120	120	120
WORK AREAS	530	530	530	530	530
Cataloguing room.....	150	150	150	150	150
Acquisition room.....	180	180	180	180	180
Work room.....	200	200	200	200	200
ACTIVE STORAGE	2,800	2,800	2,800	2,800	2,800
Book stacks.....	2,500	2,500	2,500	2,500	2,500
Microfilm library.....	200	200	200	200	200
Tape library.....	100	100	100	100	100

Table D-3
SPACE ALLOCATIONS FOR COMMON FACILITIES
ETV AND VISUAL AIDS DEPARTMENTS

TYPE OF AREA	SIZE OF ENTERING CLASS									
	In schools with facilities for ALL BASIC SCIENCES				In schools with facilities for CLINICALLY-ORIENTED BASIC SCIENCES ONLY					
	112	96	80	64	48	112	96	80	64	48
Net square feet—all areas.....	4,790	4,590	3,660	2,830	2,510	4,190	4,090	3,260	2,520	2,320
ETV DEPARTMENT	2,650	2,550	2,200	1,650	1,500	2,550	2,550	2,200	1,650	1,500
Studio.....	1,300	1,300	1,300	1,300	1,300	1,300	1,300	1,300	1,300	1,300
Control room.....	150	150	100	100	100	150	150	100	100	100
Equipment room.....	200	200	150	100	100	200	200	150	100	100
Electronic shop.....	200	200	150	100	100	200	200	150	100	100
Storage (props).....	300	300	150	150	100	300	300	150	150	100
Offices.....	300	300	200	200	200	300	300	200	200	200
Secretary and files.....	200	200	200	200	200	200	200	200	200	200
VISUAL AIDS DEPARTMENT	2,140	2,040	1,460	1,180	1,010	1,640	1,540	1,060	870	820
Graphic illustration studio.....	400	400	200	200	200	300	300	100	100	100
Graphic illustration storage.....	100	100	100	100	100	100	100	100	100	100
Equipment storage.....	200	200	100	100	100	100	100	100	100	100
Slide and film storage.....	120	120	120	80	60	120	120	120	50	50
Photographic studio.....	420	420	420	300	200	320	320	220	120	120
Dark room.....	100	100	100	100	100	100	100	100	100	100
Utility, finishing and photo-micrographic.....	200	200	200	100	100	200	200	100	100	100
Offices.....	400	300	120	100	100	300	200	120	100	100
Secretary and files.....	200	200	100	100	50	100	100	100	100	50

**Table D-4
SPACE ALLOCATIONS FOR COMMON FACILITIES
ANIMAL QUARTERS**

TYPE OF AREA	SIZE OF ENTERING CLASS						
	In schools with facilities for ALL BASIC SCIENCES						
	112	96	80	64	48	In schools with facilities for CLINICALLY-ORIENTED BASIC SCIENCES ONLY	
Net square feet--all areas	6,900	5,700	4,700	3,500	2,500	2,525	1,575
Holding rooms	5,000	4,000	3,000	2,000	1,000	1,500	600
Food preparation	200	200	200	200	200	75	75
Food storage	100	100	100	100	100	100	100
Bedding storage	300	200	200	100	100	100	75
Isolation	300	200	200	100	100	100	75
Cage washing	400	400	400	400	400	150	150
Laboratory	200	200	200	200	200	100	100
Office	100	100	100	100	100	100	100
Operatory	200	200	200	200	200	200	200
Locker room	100	100	100	100	100	100	100

Table D-5
SPACE ALLOCATIONS FOR COMMON FACILITIES
TECHNICAL SHOPS

TYPE OF AREA	SIZE OF ENTERING CLASS									
	In schools with facilities for ALL BASIC SCIENCES			In schools with facilities for CLINICALLY ORIENTED BASIC SCIENCES ONLY						
	112	96	80	64	48	112	96	80	64	48
Net square feet--all areas.....	2,000	2,000	1,400	1,200	1,000	1,600	1,600	1,100	1,000	800
Dental equipment maintenance and research.....	1,200	1,200	800	800	600	1,200	1,200	800	800	600
Central technical shops--other scientific equipment.....	800	800	600	400	400	400	400	300	200	200

E. GENERAL SUPPORTING FACILITIES

Table E-1
SPACE ALLOCATIONS FOR GENERAL SUPPORTING FACILITIES
ADMINISTRATION

TYPE OF AREA	SIZE OF ENTERING CLASS					
	In schools with facilities for ALL BASIC SCIENCES			In schools with facilities for CLINICALLY ORIENTED BASIC SCIENCES ONLY		
	112	96	80	64	48	
Net square feet—all areas.....	5,700	5,300	4,900	4,300	3,800	3,600
Dean's office.....	500	500	500	500	500	500
Assistant dean.....	300	300	300	300	300	300
Secretarial offices.....	400	400	400	400	400	400
Conference room.....	500	500	500	500	500	500
Research coordinator.....	200	200	200	200	200	200
Graduate and postgraduate.....	200	200	200	200	200	200
Dental hygiene.....	300	300	300	300	300	300
Part-time faculty.....	300	300	300	300	300	300
Conference rooms.....	1,200	1,000	800	700	600	600
Registrar and administration.....	200	200	200	200	200	200
Administrative director of clinics.....	200	200	200	200	200	200
Social services.....	300	300	250	250	150	150
Alumni office.....	500	300	300	250	150	150
Stock, mailroom, and publications.....	400	400	300	250	150	150
Steno-typist pool.....			250	250	150	150

Table E-2
SPACE ALLOCATIONS FOR GENERAL SUPPORTING FACILITIES
SPECIAL FACILITIES FOR STUDENTS AND FACULTY

TYPE OF AREA	SIZE OF ENTERING DENTAL CLASS				
	In schools with facilities for ALL BASIC SCIENCES				
	112	96	80	64	48
Net square feet—all areas.....	13,600	12,100	10,300	8,700	7,300
Locker rooms (men).....	4,000	3,500	2,900	2,300	1,900
Locker rooms (women).....	500	400	300	200	100
Toilets and shower room.....	900	800	700	600	500
Lounges.....	2,400	2,200	2,000	1,800	1,500
Laundry room.....	200	200	200	200	200
Reading rooms and study area.....	1,600	1,400	1,200	1,000	800
Student organizations and publications.....	400	400	200	200	200
Snack Bar.....	1,800	1,600	1,400	1,200	1,000
Bookstore.....	900	800	700	600	500
Faculty lounge.....	900	800	700	600	600

TYPE OF AREA	SIZE OF ENTERING DENTAL CLASS				
	In schools with facilities for CLINICALLY ORIENTED BASIC SCIENCES ONLY				
	112	96	80	64	48
Net square feet—all areas.....	12,000	10,700	9,100	7,700	6,500
Locker rooms (men).....	4,000	3,500	2,900	2,300	1,800
Locker rooms (women).....	500	400	300	200	100
Toilets and shower room.....	900	800	700	600	500
Lounges.....	2,400	2,200	2,000	1,800	1,500
Laundry room.....	200	200	200	200	200
Reading rooms and study area.....	400	400	200	200	200
Student organizations and publications.....	1,800	1,600	1,400	1,200	1,000
Snack Bar.....	900	800	700	600	500
Bookstore.....	900	800	700	600	600

Table E-3
SPACE ALLOCATIONS FOR GENERAL SUPPORTING FACILITIES
GENERAL MAINTENANCE AND BUILDING SERVICES

TYPE OF AREA	SIZE OF ENTERING CLASS									
	In schools with facilities for ALL BASIC SCIENCES			In schools with facilities for CLINICALLY-ORIENTED BASIC SCIENCES ONLY						
	112	96	80	64	48	112	96	80	64	48
Net square feet—all areas.....	15,700	13,500	11,600	9,300	7,700	14,700	12,500	10,800	8,600	7,000
Plant engineer's office.....	200	200	100	100	100	200	200	100	100	100
Purchasing office.....	100	100	100	100	100	100	100	100	100	100
Telephone equipment room and PBX.....	800	600	600	400	400	800	600	600	400	400
Receiving and shipping.....	500	500	500	400	400	500	500	500	400	400
Trash room and incinerator.....	500	400	400	400	300	500	400	400	400	300
Maintenance shops.....	1,000	800	600	400	400	900	700	600	400	400
Housekeeping services.....	1,600	1,500	1,400	1,200	1,000	1,600	1,500	1,400	1,200	1,000
General storage area.....	6,000	5,000	4,000	3,000	2,000	5,500	4,500	3,500	2,500	1,500
Laundry collection.....	400	400	300	200	200	400	400	300	200	200
Employees' locker room.....	800	700	600	500	400	800	700	600	500	400
Mechanical space.....	1,400	1,200	1,200	1,000	1,000	1,200	1,000	1,000	900	900
Employee toilet rooms.....	200	200	200	200	200	200	200	200	200	200
Staff toilet rooms.....	600	500	400	400	400	400	300	300	300	300
Public toilet rooms.....	1,600	1,400	1,200	1,000	800	1,600	1,400	1,200	1,000	800

F. DENTAL AUXILIARY PROGRAMS

Table F-1
SPACE ALLOCATIONS FOR DENTAL AUXILIARY PROGRAMS
DENTAL HYGIENIST (2-YEAR) PROGRAM

TYPE OF AREA	SIZE OF ENTERING DENTAL HYGIENE CLASS		
	64	48	32
Net square feet—all areas.....	12,800	9,900	7,200
Laboratory.....	2,600	2,100	1,600
Processing laboratory *.....	400	300	300
Storage.....	300	200	100
Offices.....	800	600	500
Classroom or seminar space.....	900	600	300
Operatories (1 per EGS).....	6,400	4,800	3,200
Lounge, lockers and toilets.....	1,400	1,300	1,200

*Optional—hygiene student may use dental student facilities.

Table F-2
SPACE ALLOCATIONS FOR DENTAL AUXILIARY PROGRAMS
DENTAL ASSISTANT (1-YEAR) PROGRAM

TYPE OF AREA	SIZE OF ENTERING DENTAL ASSISTANTS CLASS		
	64	48	32
Net square feet—all areas.....	6,000	4,900	3,700
Laboratory classroom.....	2,600	2,100	1,600
Storage.....	300	200	100
Offices.....	300	300	200
Seminar rooms.....	900	600	300
Demonstration operatory.....	700	700	700
Lounge, lockers and toilets.....	1,200	1,000	800

III LIST OF FLOOR PLANS AND PHOTOGRAPHS

	PAGE
Figure 1. Building Module.....	21
Figure 2. Modular planning of research areas.....	22
Figure 3. Plan for a basic science area utilizing a central utility core.....	24
Figure 4. Space relationships—preclinical and clinical dental science areas.....	26
Figure 6A. Layout and equipment of unit laboratory for both basic and preclinical sciences.....	30
Figure 7. 16-man laboratory.....	31
Figure 10. Layout of anatomy laboratory of class size.....	38
Figure 13. Preclinical laboratory of 96 student positions utilizing closed circuit TV for demonstrations.....	42
Figure 15. Dental clinic flow diagram.....	44
Figure 16. Radiology clinic.....	47
Figure 18. Oral surgery department.....	50
Figure 24A. Open clinic.....	53
Figure 24B. Cubicle clinic.....	53
Figure 25. Variation of cubicle clinic.....	54
Figure 26. Cubicle clinic for utilizing dental auxiliary personnel.....	55
Figure 27. A cubicle for student working alone.....	56
Figure 28A. A cubicle for student and dental assistant.....	56
Figure 28B. Variation for student-assistant team.....	57
Figure 39. ETV and visual aids departments.....	66
Figure 40. Central laboratory services department.....	68
Figure 42. Departmental office and research area.....	73
Figure 43. Administration area.....	79

PHOTOGRAPHS

	PAGE
Figure 5. Departmental laboratory for research in histology--	29
Figure 6B. Freshman unit laboratory equipped with TV monitor.....	31
Figure 8. Low bench laboratory, where the microscope is the principal tool.....	32
Figure 9. High bench laboratory equipped with folding partitions for greater flexibility of use.....	34
Figure 11. Preclinical laboratory benches with individual storage drawers and lamps.....	41
Figure 12. Conventional arrangement of preclinical laboratory benches, with dental motors and utility outlets at each position.....	41
Figure 14. General clinic typical of many dental schools.....	44
Figure 17. In cubicle clinics partitions separate each workstation.....	48
Figure 19. Clinical processing laboratory with bailout tanks and lathes.....	51
Figure 20. Benches in an orthodontics laboratory designed for graduate work.....	51
Figure 21. Ovens and centrifuges used in casting metal restorations.....	51
Figure 22. An open clinic, with stands for students' instrument cases.....	52
Figure 23. The cubicle clinic, favored by many dental educators.....	52
Figure 29. Cubicle clinic with low partitions where chairs face the aisle.....	57
Figure 30. Cabinets are sometimes used to separate work stations in an open clinic.....	57
Figure 31. Wide, well-lighted corridor in a modern dental school. The splayed walls reduce sound reverberation within adjoining lecture rooms.....	60
Figure 32. Lecture room equipped for ETV.....	61
Figure 33. Individual study cubicles give students a private, assigned study area.....	62
Figure 34. Library reading room for dental students.....	63
Figure 35. Demonstration operatory in an ETV studio.....	64
Figure 36. TV microscopy—a valuable teaching aid.....	64
Figure 37. View of ETV studio through control room observation panel.....	65
Figure 38. ETV control room with program director at controls console.....	65
Figure 41. Animal quarters with cages supported on an overhead trolley system.....	69
Figure 44. Student lounge—attractive and comfortable.....	80

IV REFERENCES

1. American Council on Education, *Survey of Dentistry*. (Final report of the Commission on the Survey of Dentistry in the United States.) Washington, 1961.
2. Netsch, Walter A., *Buildings for Research*. New York: F. W. Dodge Corporation, 1958.
3. Federal Aviation Agency, *Aircraft Noise Abatement, Planning Series Item No. 3*. Washington: Government Printing Office, 1960.
4. Adams, Myron W., and Prentice Bradley, *A62 Guide for Modular Coordination*. Boston: Modular Service Association, 1946.
5. U.S. Department of Health, Education, and Welfare, Public Health Service, *Medical School Facilities: Planning Considerations and Architectural Guide*, Public Health Service Publication No. 875. Washington: Government Printing Office, 1961.

V SELECTED BIBLIOGRAPHY

- American Council on Education. *Survey of Dentistry*. (Final Report of the Commission on the Survey of Dentistry in the United States.) Washington: The Council, 1961.
- Barker, E. Vernon. "Design and Construction of Animal Quarters for Medical Education and Research," *Journal of Medical Education*, XXXV (January 1960), 15-23.
- Braestrup, C. B., and H. O. Wyckoff. *Radiation Protection*. Springfield: Charles Thomas, 1958.
- Brumbaugh, A. J. *Research Designed To Improve Institutions of Higher Learning*. Washington: American Council on Education, 1960.
- Cohen, Bennett J. "Organization and Function of a Medical School Animal Facility," *Journal of Medical Education*, XXXV (January 1960), 24-33.
- Costello, Lawrence F., and George M. Gordon. *Teach With Television*. New York: Hastings House, 1961.
- Cowgill, Clinton H., and Ben J. Small. *Architectural Practice*. 3d Edition. New York: Reinhold Publishing Corporation, 1959.
- Educational Facilities Laboratories. *Design for ETV*. New York: The Laboratories, 1960.
- Ellsworth, Ralph E. *Planning the College and University Library Building*. Boulder: Pruett Press, Inc., 1960.
- Federal Aviation Agency. *Aircraft Noise Abatement*. (Planning Series Item No. 3.) Washington: Processed, 1960.
- Greene, A. "The Medical School Bookstore," *Journal of Medical Education*, XXXV (May 1960), 454-458.
- Handles, A. Benjamin. *Economic Planning for Better Schools*. Ann Arbor: University of Michigan Press, 1959.
- Lewis, Harry F. *Laboratory Design*. (National Research Council Report.) New York: Reinhold Publishing Corporation, 1961.
- National Educational Television and Radio Center. *The Impact of Educational Television*. Urbana: University of Illinois Press, 1960.
- National Naval Medical Center. *Medical-Dental Television Workshop*. Bethesda: Processed, 1960.
- Netsch, Walter A. *Buildings for Research*. New York: F. W. Dodge Corporation, 1958.
- Nuffield Foundation. *The Design of Research Laboratories*. London: Oxford University Press, 1961.
- Palmer, R. Ronald, and William M. Rice. *Modern Physics Buildings*. New York: Reinhold Publishing Corporation, 1961.
- Portland State College, Division of Education. *Planning Schools for New Media*. Portland: The College, 1961.
- Publications of the Institute for Advancement of Medical Communication, 33 East 68th Street, New York 21, New York.
- Radiodent Processing Rooms*. Rochester: Eastman Kodak Company, 1959.
- Rosenfield, Isadore. *Hospitals—Integrated Design*. New York: Reinhold Publishing Corporation, 1947.
- Russell, John D., and I. Doi Jones. *Manual for Studies of Space Utilization in Colleges and Universities*. Athens, Ohio: American Association of Collegiate Registrars and Admission Officers, Ohio University, 1957.
- Scott, Wendell G. *Planning Guide for Radiologic Installations*. Chicago: The Year Book Publishers, Inc., 1953.
- Smith, Hinchman and Grylls, Assoc. "Organization for Efficient Practice," *Architectural Record*, CXXIX-II (August 1960), 165-170.

- Thorp, W. T. S. "The Design of Animal Quarters," *Journal of Medical Education*, XXXV (January 1960), 4-14.
- U.S. Atomic Energy Commission. "Standards for Protection Against Radiation," *U.S. Federal Register*, January 29, 1957. Part 20, Chapter 1, Title 10.
- U.S. Department of Commerce. National Bureau of Standards. *Control and Removal of Radioactive Contamination in Laboratories*, National Bureau of Standards Handbook No. 48. Washington: Government Printing Office, 1951.
- Medical X-Ray Protection Up to Three Million Volts*, NBS Handbook No. 76. 1961.
- Recommendations for Waste Disposal of Phosphorus-32 and Iodine-131 for Medical Users*, NBS Handbook No. 49. 1951.
- Safe Handling of Radioactive Isotopes*, NBS Handbook No. 42. 1949.
- U.S. Department of Health, Education, and Welfare. Public Health Service. *Medical School Facilities*, Public Health Service Publication No. 875. Washington: Government Printing Office, 1961.
- University Facilities Research Center. *Horizontal and Vertical Circulation in University Instructional and Research Buildings*. Madison, Wisconsin: Educational Facilities Laboratories, Inc., 1961.
- Parking Programs for Universities*. 1961.
- Plumbing Fixture Requirements in University Instructional and Research Buildings*. 1961.
- University Research Buildings for Short-Term Grant Programs*. 1961.
- Willard, William R. "New Medical Schools: Some Preliminary Considerations," *Journal of Medical Education*, XXXV (February 1960), 93-107.
- X-Rays in Dentistry*. Rochester: Eastman Kodak Company, 1959.
- Zimmerman, William V. *School Planning Laboratory Research, Report No. 1*. Stanford: Western Regional Center, Educational Facilities Laboratories, 1960.